

FOXPRO®

High Performance Game Calls



SHOCKWAVE™

Instruction Manual

FOXPRO Inc. • 14 Fox Hollow Drive • Lewistown, PA 17044 • (717)-248-2507

www.gofoxpro.com

Important Information

FOXPRO®'s goal is to provide our customers with the highest quality products in the industry. We take great pride in manufacturing our products in the USA. Please do not hesitate to contact us for assistance, comments or questions.

FOXPRO® Inc.

14 Fox Hollow Drive
Lewistown, PA 17044
(717) 248-2507
Fax: (717) 247-3594

Hours of Operation

Monday – Friday
8AM – 5PM EST

Contact Us

Customer Service: (717) 248-2507
Toll Free Orders Only: 866-463-6977
General Inquiry E-mail: sales@gofoxpro.com

Stay up to date with the latest sounds by visiting our online sound library. Watch for new products and upgrades from FOXPRO®. Visit us online:

www.gofoxpro.com



This manual, the animal sounds stored in your caller, and animal sounds purchased from FOXPRO® Inc. for installation in your caller is protected by copyright.

Publication Date: June 13, 2014
Copyright ©© 2014 by FOXPRO® Inc.
REV5

Contents

1. Getting Started.....	7
1-1 What's in the Box?	7
1-2 Shockwave: First Glance.....	7
1-3 Shockwave: Requirements.....	8
1-4 Shockwave Remote: First Glance	9
1-5 Shockwave Remote: Requirements	10
2. Quick Start Guide	11
2-1 Playing Sounds Manually.....	11
2-2 Shockwave Remote Setup.....	11
2-3 Playing Sounds Remotely	12
2-4 Using Presets/Favorites.....	13
3. Shockwave Manual Operation.....	14
3-1 Turning on the Power.....	14
3-2 Understanding the Screen.....	14
3-3 Navigating the Shockwave	15
3-4 Playing Sounds Manually.....	15
3-5 Moving the Speakers.....	15
3-6 Using a Tripod	15
3-7 Accessing the Shockwave Parameter Menu	15
3-8 Parameter Menu: Options & Details.....	16
3-9 Charge Jack Specifications.....	16
3-10 External Speaker Jacks Specifications	18
3-11 Auxiliary Device Jack Specifications	18
3-12 Integrated Mini USB Port	18
4. Shockwave Remote Operation	19

4-1	What are FOX FEATURES?	19
4-2	Turning on the Shockwave Remote	19
4-3	Navigating the Shockwave Remote.....	19
4-4	Understanding the Shockwave Remote Display	19
4-5	Accessing Shockwave Remote Configuration Menu	21
4-6	Verifying Channel of Operation.....	24
4-7	Playing Sounds with the Remote	24
4-8	Volume & Mute Control	25
4-9	Presets / Favorites.....	26
5.	FOX FEATURES.....	26
5-1	FOXFUSION.....	27
5-2	FOXMOTION	28
5-3	FOXBANG.....	29
5-4	FOXPITCH.....	30
5-5	AUTO VOLUME.....	30
5-6	User Button	31
5-7	FOXDATA	31
5-8	FOXGRIP	33
6.	Sound Settings	34
6-1	Volume Step	34
6-2	Primary & Secondary (FOXFUSION) Mode	34
6-3	Speaker Mode	34
6-4	Right and Left Speaker	35
6-5	Preset Mute Override.....	35
7.	Display / Power	36
7-1	Brightness.....	36

7-2	Keypad.....	36
7-3	Theme.....	36
7-4	Display Timeout.....	37
7-5	Auto Off.....	37
8.	Date / Time(r).....	37
8-1	Stand Timer & Timer Reset	38
8-2	Alarm	38
8-3	Time.....	38
8-4	Date & Date Format	39
9.	TX1000 Settings.....	40
9-1	Radio Channel	40
9-2	Download List.....	40
9-3	AUX.....	40
9-4	View.....	41
9-5	Temperature Units	41
9-6	Barometer Measurement Units	41
9-7	Elevation.....	41
9-8	About Info	42
9-9	Restore Defaults.....	42
10.	Shockwave Remote USB Operation	42
10-1	Editing the Presets File	43
10-2	Viewing the FOXDATA File.....	44
11.	Programming the Shockwave	44
11-1	Requirements.....	44
11-2	Connecting to a Computer	45
11-3	Manual Programming Process	46

11-4	Indexing the Files.....	46
11-5	Using the FOXPRO Programming Utility.....	47
11-6	Editing the Categories Manually	48
11-7	Editing the Categories with FOXPRO Utility	49
11-8	Updating the Remote Playlist.....	50
12.	Creating FOXCAST Sequence Files	50
12-1	Creating FOXCAST Sequences Manually	51
12-2	Enabling File Extensions in Windows	52
12-3	Placing Sequences in the Shockwave	52
12-4	Creating FOXCAST Sequences Online.....	53
12-5	Synchronizing the Shockwave Remote	53
13.	Firmware Updates.....	53
13-1	Shockwave Digital Game Call (V1.5 and higher)	53
13-2	Shockwave TX1000 Remote	54
14.	Product Care & Maintenance.....	55
15.	Troubleshooting	56
16.	Maximizing Remote Range	57
17.	FCC & IC Information.....	58
18.	Warranty Statement	59

1. Getting Started

Congratulations on your purchase of the FOXPRO Shockwave digital game call! The Shockwave is a sophisticated tool that redefines what a digital game call is capable of. It is packed with exciting new features enabling you to take control of your hunts like never before. To get the full advantage of the Shockwave and its array of capabilities, please read and understand the operating instructions in full.

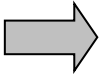

WARNING: To avoid personal injury and product damage, read all operating instructions and safety precautions in this guide before using the FOXPRO Shockwave digital game call system. A digital copy of this file can be downloaded from:
<http://www.gofoxpro.com/resources/manuals/Shockwave-manual.pdf>

1-1 What's in the Box?

Included with the box you should find the following list of items:

- 1) Shockwave digital game call
- 2) Shockwave remote control
- 3) Operators manual
- 4) Warranty registration card
- 5) Mini-USB Cable

1-2 Shockwave: First Glance

The graphic on the next page depicts the Shockwave. Certain aspects of the Shockwave will be marked with a number which corresponds to the chart defining that particular element.

Number	Description
1	Left horn and tweeter speakers
2	Power on/off and manual volume control
3	Graphic display
4	Sound up / menu navigation button
5	Play / menu / select button / Mute (pause)
6	Sound down / menu navigation button
7	Right horn and tweeter speakers
8	Rugged ABS housing
9	Auxiliary device jack
10	Right external speaker jack
11	Mini USB port
12	Left external speaker jack
13	Charge jack
14	Speaker connector straps

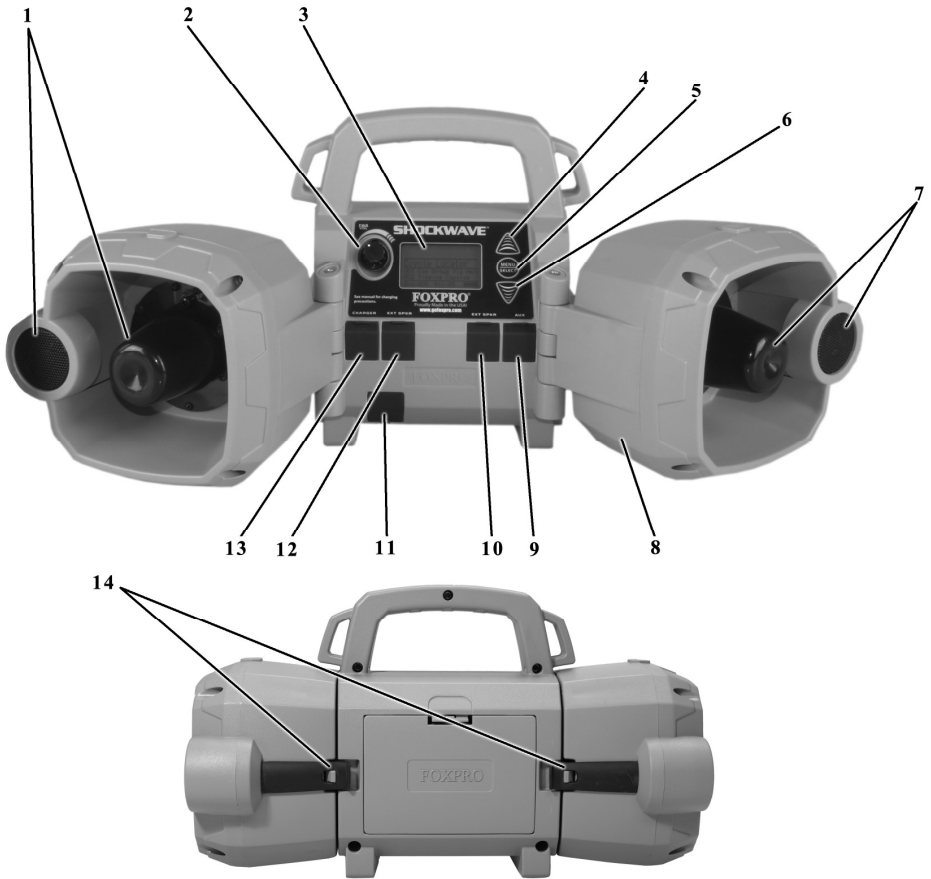

Figure 1-1 Shockwave Digital Game Call

1-3 Shockwave: Requirements

The Shockwave and Shockwave remote control are shipped without batteries. The Shockwave digital game call requires 10 'AA' batteries. You may use alkaline batteries to get started, but it is recommended that you use high capacity rechargeable NiMH (nickel metal hydride) batteries or one of FOXPRO's optional rechargeable battery packs. Visit our website to view the entire line of recharging options for the Shockwave.



IMPORTANT NOTE

Some users may prefer using an external 12V sealed lead acid battery. When using such a battery, make sure that you select battery type "NiMH" within the Shockwave parameter menu. Please view page 16 for locating the appropriate setting in the menu.

Installing Batteries in the Shockwave

1. Access the battery compartment by removing the door on the back of the Shockwave. Once the door is removed, locate the black plastic battery tray. This tray is double-sided, providing spaces for 10 'AA' batteries. The tray is connected to a power cable inside of the Shockwave. You may unplug this cable and remove the tray from the caller during battery installation.
2. Place the batteries into each battery cavity while observing polarity as indicated.
3. Reconnect the power cable to the tray and place the tray back into the Shockwave.
4. Secure the door back to the Shockwave.

After the batteries are installed, you must select the appropriate battery type in the Shockwave configuration menu. To accomplish this:

1. Turn on the Shockwave.
2. Access the main menu by pushing and holding the "Menu/Select" button for approximately 3-4 seconds.
3. Scroll through the menu options until you locate "Battery Type".
4. Push the "Menu/Select" button a single time and then use the scroll buttons to cycle through the available options. Options include Alkaline, Li-Cells, Li-Pack, and NiMH.
5. Once you have selected the appropriate battery type, push the "Menu/Select" button to lock it in.

1-4 Shockwave Remote: First Glance

The following chart corresponds to a graphic on the next page that depicts the Shockwave remote. Certain aspects of the Shockwave remote will be marked with a number which corresponds to the chart defining that particular element.

Number	Description	Number	Description
1	Quick access preset buttons	11	Recall button
2	FOXDATA button	12	Auxiliary button
3	Power on/off button	13	Mute button
4	Scroll up button	14	Volume up button
5	Volume down button	15	Back / menu button
6	Play / select button	16	FOXFUSION button
7	Scroll down button	17	Mini USB Port
8	FOXPITCH		
9	USER button		
10	Lanyard loop		

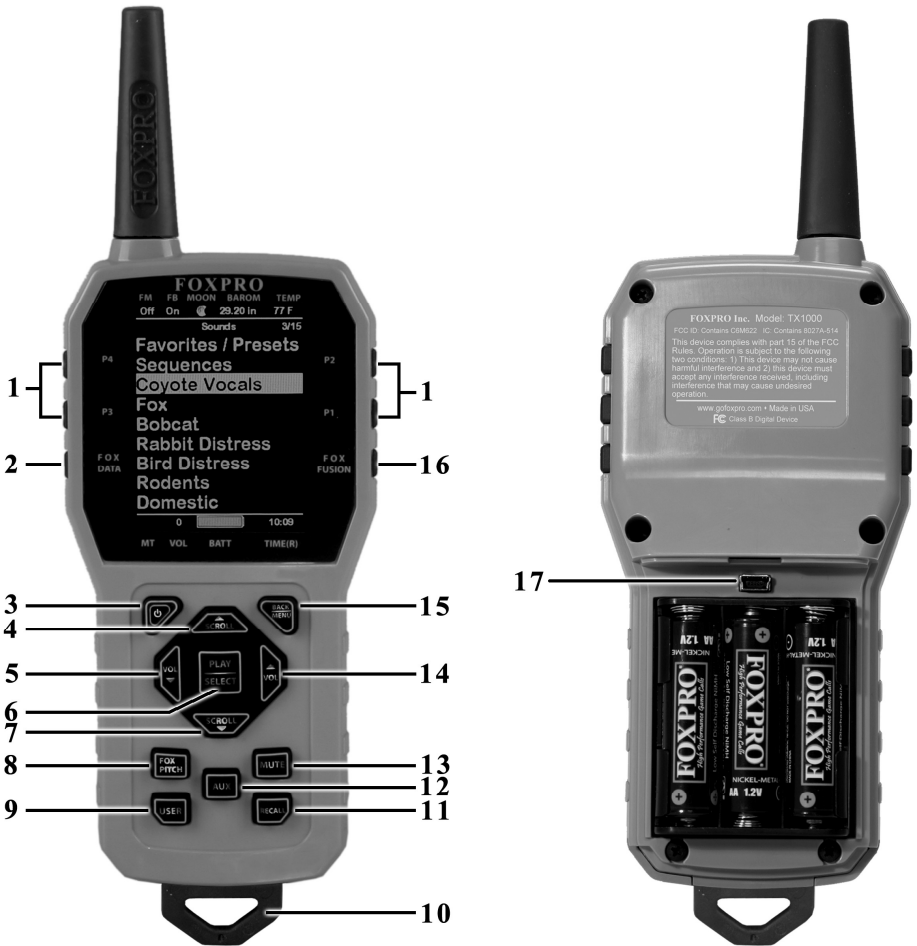

Figure 1-2 Shockwave Remote Control

1-5 Shockwave Remote: Requirements

The Shockwave remote control operates on 3 'AA' batteries. It is recommended that you use high quality lithium or alkaline batteries for the best performance.

Installing Batteries in the Shockwave Remote

1. Access the battery compartment by removing the door from the back of the remote. The door slides down and off of the remote.
2. Place the batteries into each battery cavity while observing polarity as indicated.
3. Slide the battery compartment door back on the remote.

2. Quick Start Guide

The Shockwave user manual is rather lengthy, covering all aspects of the Shockwave and remote control. We realize that some of you may wish to jump directly into basic operations, such as playing sounds manually, remotely, and using presets. This is a very brief overview and it is strongly recommended that you read this manual entirely in order to fully understand all capabilities of the system.

2-1 Playing Sounds Manually

After installing batteries as described in Chapter 1, turn on the Shockwave by rotating the volume/power knob clockwise. The on-board display will activate and show system information during the power-on cycle.

After it is fully powered, the sound list will be displayed. Use the scroll buttons, on the front of the Shockwave, to scroll through the available sound list. When you find a sound you wish to play, simply push the “Menu/Select” button to initiate playback.

You can then use the volume knob to adjust volume up or down to a desired level. By pushing the “Menu/Select” button a single time while a sound is playing, you can mute the sound. A subsequent press will un-mute. To begin playback of a different sound, simply scroll through the list, find the sound, and push the “Menu/Select” button.

For more detailed information on manual operations and Shockwave configurations, please continue on to Chapter 3.

2-2 Shockwave Remote Setup

After installing batteries or changing batteries in the Shockwave remote, it is recommended that you make it a routine to take a moment to setup the date and time settings. This section will explain these setup configurations.

Setting the Clock:

1. Access the Date/Time(r) menu and select “Time”
2. Use the scroll buttons to set the current time.
3. Push “Play/Select” to lock it in.

The clock can be displayed in either the standard 12 hour format or 24 hour format (military time).

Configuring Time Format:

1. Access the Date/Time(r) menu and select “Time Format”
2. Use the scroll buttons to select either 12 or 24 hour time format.
3. Push “Play/Select” to lock in the setting.

The bottom status line of the Shockwave display can show either the current time or the stand timer. The stand timer will only be displayed if it is turned on—otherwise, the clock will show the current time.

The Shockwave remote will keep track of the current date in order to properly render moon phases. This needs to be setup when you first start using the Shockwave remote.



IMPORTANT NOTE

The Shockwave remote control features a moon phase indicator. In order to display the correct moon phase, it is imperative that you enter the correct date. Otherwise, the displayed information may not be correct.

Setting the Date:

1. Access the Date/Time(r) menu and select “Date”
2. By default, the first option is the month. Use the scroll buttons to select the current month and then push the “Play/Select” button.
3. Next you set the day using the same method described above, and then push “Play/Select”.
4. Finally, set the year and push “Play/Select” to lock it in.

There are three different date formats that you can choose from depending upon your personal preference. They are month/day/year, year-month-day, and day.month.year.

Configuring Date Format:

1. Access the Date/Time(r) menu and select “Date Format”
2. Use the scroll buttons to cycle through the options.
3. When your desired date format is shown, push “Play/Select” to lock it in.

2-3 Playing Sounds Remotely

Make sure that you have properly installed batteries in both the Shockwave and Shockwave remote as described within Chapter 1. Turn on the Shockwave by turning the volume/power knob clockwise. Turn on the Shockwave remote by pushing and holding the power button for approximately about 1-2 seconds. When powered on, the Shockwave on-board display will show the sound list. The Shockwave remote default view will display the available categories.

Using the scroll buttons on the Shockwave remote, highlight the category you wish to pick a sound from, and then push the “Play/Select” button. The sounds assigned to that category will now be displayed. Use the scroll buttons to highlight a sound that you wish to play, and then push the “Play/Select” button to begin playback. You then must use the volume up button to raise the volume level to your desired setting.

To mute the sound, simply push the “Mute” button. Un-muting is accomplished by pushing the “Mute” button a second time. You can quickly change to a different sound by highlighting it on the screen and then pushing the “Play/Select” button. To quickly go back to the previous sound, you can push the “Recall” button.

For more detailed information on remote operations and configuration, please continue to Chapter 4.

2-4 Using Presets/Favorites

The Shockwave remote is capable of storing up to 50 unique presets or favorites. A preset is a shortcut to a particular sound which has a defined volume level. The Shockwave remote has 4 quick access preset buttons located on the top left and right (see image 1-2 in Chapter 1).

By default, your Shockwave remote will have no presets established. The following instructions will describe how to setup a preset:

To Create a Preset/Favorite:

1. From the main screen, select the “Favorites/Presets” menu item.
2. Select one of the 50 preset slots. Notice that the screen will indicate “Preset Recording”. The first step is to select the sound.
3. Use the scroll buttons to highlight the sound you want to establish for this preset and then push the “Play/Select” button.
4. The last step is setting the volume level. Use the volume buttons to dial-in the desired volume level you wish to assign to this preset and then push “Play/Select” to lock it in.
5. Your preset is now setup.

You can assign the P1, P2, P3, and P4 buttons in the following manner:

1. Highlight the sound that you wish to have established in one of the four positions.
2. From the main sounds or category screen, press and hold the P1, P2, P3, or P4 button for approximately 3-4 seconds.
3. Set the volume level and then push the “Play/Select” button to lock in that preset.

To initiate playback of preset 1-4, make sure that both the Shockwave and Shockwave remote are turned on, and then push the corresponding preset button (P1 – P4) on the top sides of the remote. The Shockwave will then instantly switch to that sound and volume level.

To initiate playback of any preset, simply select the “Favorites/Presets” menu on the main screen, browse through the available presets, and then use the “Play/Select” button, just as if you were picking a sound for normal playback.

Presets can also be managed by editing a specific file located within the Shockwave remote. For the advanced information on this process, please view Chapter 10.

3. Shockwave Manual Operation

The most basic method of operating the Shockwave digital game call is manually or without using the Shockwave remote control. It is recommended that you begin with manual operation before starting to work with the Shockwave remote.

3-1 Turning on the Power

After installing batteries as instructed in Chapter 1, you are ready to turn on the Shockwave digital game call. To turn on the Shockwave, locate the knob on the upper-left corner of the Shockwave faceplate (refer to figure1-1 on page 8). Turn this knob clockwise (to the right) until you hear a soft click. Once fully powered, the screen will show the first three sounds and the bottom status line.

3-2 Understanding the Screen

The Shockwave on-board display shows a lot of information. The image below represents the screen. The main display elements are numbered and described in the following chart.

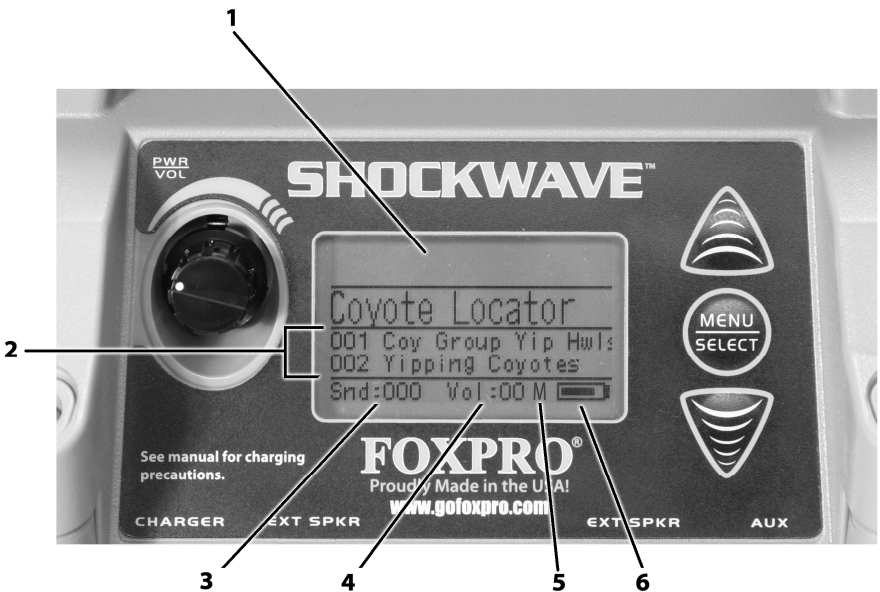

Figure 3-1 Shockwave Front View

Number	Description
1	Shockwave display
2	Sound list (displays names or names and numbers depending upon setup)
3	Sound indicator displays the currently selected sound or FOXCAST file
4	Volume level indicator

5	Mute status indicator
6	Battery level indicator

3-3 Navigating the Shockwave

The up and down scroll buttons (located to the right of the on-board display) allow you to step through your sound list and menu options. The “Menu/Select” button provides triple function operation. It is used for starting sound playback, muting sound playback, and entering the Shockwave menu.

3-4 Playing Sounds Manually

Scroll through the sound list using the scroll buttons. The current sound will be in a larger font than the rest and it will have a horizontal bar above and below the name. Select the sound you wish to play and then push the “Menu/Select” button. Notice the volume level indicator on the screen—as soon as the “Menu/Select” button is pushed, the selected sound will begin playing at the volume level indicated. Use the volume knob to increase or decrease the volume level. The displayed volume level will rise or fall in response to the knob movement. To pause or mute the sound, push the “Menu/Select” button again. When muted, the letter “M” will appear to the right of the volume level.

3-5 Moving the Speakers

The Shockwave speakers are secured to the back of the Shockwave housing by rubber straps. You can release the straps from their mounting points to move the speakers. The speakers can be moved from the side-facing position to pointing directly forward or any point there in between. This allows you to direct the sound in a particular direction.

When travelling with the Shockwave between stands, it is recommended that you connect the speaker straps back to their mounting points on the back of the Shockwave to help prevent them from swinging around.

3-6 Using a Tripod

The Shockwave features a universal tripod mount located on the bottom of the device. This mount will work with most tripods using the universal-type tripod connector. Using a tripod can be helpful in two ways. First, elevating the caller off the ground can help sound propagation by lessening the dampening of the emitted sound to the ground. Second, elevation can be helpful in maximizing the remote range.

3-7 Accessing the Shockwave Parameter Menu

To access the Shockwave menu, push and hold the “Menu/Select” button for approximately 3-4 seconds. The menu will then display. Navigating the menu is done by using the scroll buttons and making a selection is done by pushing the “Menu/Select” button. Option values are

changed by selecting the menu item, pushing the “Menu/Select” button a single time, and then using the scroll buttons to cycle through the available values. Saving a value change is done by pushing the “Menu/Select” button a single time.

3-8 Parameter Menu: Options & Details

This section will explore all Shockwave menu items and associated values of each.

Name	Values
Exit	Exits the Shockwave menu
Contrast	Adjusts the screen contrast. Values are 1 – 10. The higher the number, the darker the text.
Backlight	Adjusts red backlight between on (always on), off (always off), and auto (shuts off after approximately 5 seconds).
Volume	Low and high. Low setting is for maximizing battery life where the high setting will maximize overall volume while sacrificing maximum battery life.
Battery Type	Select battery type to best utilize batteries. Values are NiMH (rechargeable nickel metal hydride), Alkaline (non-rechargeable), Li-Cells (disposable lithium batteries), and Li-Pack (FOXPRO’s rechargeable lithium battery pack). Note: If you are using an external 12VDC sealed lead acid battery, be sure to select NiMH as the battery type for best results.
Remote Channel	Change the Shockwave radio channel from 0 -15. Note that the Shockwave remote must be on the same channel.
File List	Changes how sound names are displayed. No Numbers results in the sound names being displayed without their numerical ID while Numbered prefixes the names with the number.
Play Mode	Sound playback mode. Choose from single (sound plays one time and stops), repeat (sound plays continuously), or jukebox (sound plays once and then moves on to the next sound).
Auto Off	Automatically shut off the Shockwave after a period of inactivity. Values are Off (disabled), 1, 2, 4, or 8 hours. Any radio traffic will reset the timer. Note: It is recommended that you disable auto shut off when using FOXCAST sequence files.

3-9 Charge Jack Specifications

This jack is designed to be used only with the FOXPRO recharging kit that includes 10 AA rechargeable batteries and 110VAC wall charger. The Shockwave digital game caller is designed to operate on 10 ‘AA’ batteries. FOXPRO has several charging accessories available for purchase. For optimal performance, it is recommended that you use high capacity (2300 mAh or higher) NiMH (Nickel Metal Hydride) rechargeable cells or FOXPRO’s rechargeable lithium battery pack rather than alkaline types.

When you operate your Shockwave to play sounds at extremely loud volume levels, the current demand on the batteries is much more than alkaline cells can deliver. Consequently, the run times for these batteries can be very short.

All FOXPRO rechargeable battery kits are shipped with individual instruction sets that pertain to their unique operations. The following list of cautions and warnings should be observed with any rechargeable system you decide to use.



WARNING

- **Never attach an unapproved or a non-FOXPRO® charger to your Shockwave!** Damages caused by plugging unapproved charging devices into your Shockwave will not be covered by warranty.
- **Never connect your Shockwave to an unregulated 12V system (i.e. automotive systems, high current power supplies, etc.)** Serious damage will occur which is not covered by the warranty. The charge jack is intended only for FOXPRO® chargers.
- **Do not mix battery types!** For example: never use NiMH rechargeable batteries in conjunction with non-rechargeable alkaline batteries.

GENERAL PRECAUTIONS FOR CHARGING

- **Never attempt to charge batteries that are not intended to be recharged!** This includes both Zinc Carbon and alkaline cells. The resulting damage can be serious and will not be covered by the warranty. For maximum charge efficiency, we recommend charging your Shockwave in temperatures ranging from 40°F to 85°F (5°C to 30°C).
- Disconnect any/all accessory devices that may be attached to the Shockwave prior to charging. This includes external speakers, auxiliary devices, and USB cables.
- Make sure that the rechargeable battery pack is installed in the Shockwave properly.
- Connect the approved FOXPRO charger to the charger jack on the Shockwave and attach the transformer to the appropriate outlet.
- Remember that NiMH batteries self-discharge about 1% per day.
- Do not leave charging batteries unattended.
- Remove batteries from battery holder when caller will not be used for prolonged periods to help prevent deep discharge.
- Recharge your batteries periodically—even when not in use—to prevent deep discharge.

3-10 External Speaker Jacks Specifications

The Shockwave features two external speaker jacks. These are standard 3.5mm female jacks that can accept a 3.5mm male plug. When selecting an external speaker to use with the Shockwave, note that FOXPRO recommends the use of a speaker with 8Ω Impedance.

FOXPRO carries a variety of external speakers for purchase that can be used with the Shockwave. You can view the line of speakers online by visiting www.godoxpro.com

Connect an external speaker to Your Shockwave:

1. Make sure that the Shockwave is powered-off before connecting an external speaker.
2. Connect the plug from the external speaker to either the left or right external speaker jack.
3. Turn on the Shockwave and begin playing a sound to hear the external speaker in action.

3-11 Auxiliary Device Jack Specifications

The Shockwave is equipped with an auxiliary jack labeled "AUX". This jack is located on the front of the Shockwave. The purpose of this jack is to allow for the connection of certain external devices (such as Jack Predator Decoys) for triggering their action on and off by using the Shockwave remote control.

While you may be able to connect other devices to the auxiliary jack beyond Jack Predator Decoys, there are strict electrical limits involved with this jack. If these limits are exceeded, damage to your Shockwave will result. That damage is not covered by warranty.

The electrically inclined will want to know that the jack is connected to the drain of an internal FET with a maximum current rating of 2A. The tip polarity of the 3.5mm jack is positive, the sleeve is negative. If the external device is connected with reverse polarity, an internal production diode within the FET will conduct causing the device to stay on constantly. The maximum voltage applied to this jack cannot exceed 15VDC.

Instructions for connecting various devices to the auxiliary jack are beyond the scope of this manual. You are urged to seek help from a knowledgeable professional before connecting any unapproved devices to the jack. Keep in mind that any damage to the Shockwave as a result of improper use of the auxiliary jack is not covered by the warranty, nor will FOXPRO be liable for damage to any connected devices.

3-12 Integrated Mini USB Port

The Shockwave features a mini USB port. The port is located beneath the charger and external speaker jack towards the left side of the front plate. This port allows you to connect a mini USB cable from the Shockwave to a USB port on a computer for performing such tasks as loading

FOXCAST sequence files and reprogramming sounds. Both of these topics will be covered in a later chapter.



IMPORTANT NOTE

When connecting the Shockwave to a home computer, make sure that the power is turned off.

4. Shockwave Remote Operation

This section covers all aspects of the Shockwave remote control.

4-1 What are FOX FEATURES?

Throughout this section, you will be introduced to a set of features that are referred to as FOX FEATURES. These features include FOXBANG, FOXCAST, FOXMOTION, FOXITCH, FOXGRIP, and FOXDATA. These features will be explained in full detail as encountered through the manual.

4-2 Turning on the Shockwave Remote

After installing batteries as indicated in Chapter 1 (pg. 10), you can turn on the Shockwave remote by pushing and holding the power button for approximately 1-2 seconds. An initial startup screen will appear showing the FOXPRO logo and remote version information. After the startup screen clears, the main sound selection screen will appear.

4-3 Navigating the Shockwave Remote

The Shockwave remote has a scroll up and scroll down button (see items 4 and 7 in figure 1-2 on pg. 10) for cycling through the on-screen display. A selected menu item is highlighted with a horizontal bar and, by pressing the scroll up or down arrow button, that horizontal bar will move up or down through the menu items list. To make menu selections, use the “Play/Select” button (see item 6 in Figure 1-2 on pg. 10). The “Back/Menu” button (see item 15 in Figure 1-2 on pg. 10) allows you to access the Shockwave Remote menu configuration and step back one level in the menu system.

4-4 Understanding the Shockwave Remote Display

The Shockwave remote control screen can be viewed in three main segments: top status line, primary display area, and bottom status line. The top and bottom status lines are static—meaning that they will always be present. The primary display area is dynamic and will change depending upon the operation that you are performing.

Top Status Line Overview

Top Status Line Overview				
FM	FB	MOON	BAROM	TEMP
Off	FB		29.20in	58 F
Name	Details			
FM	FOXOTION status indicator. Displays either On or Off.			
FB	FOXKANG status indicator / FOXGRIP status indicator. Displays “FB” if FOXKANG is activated. Displays “FG” if FOXGRIP is activated. Displays “FB/FG” if both FOXKANG and FOXGRIP are activated.			
MOON	Moon phase indicator. Displays an icon depicting the current moon phase. Correct moon phase display requires proper date and time configuration.			
BAROM	Barometer. Displays the barometric pressure in either inches or millimeters depending upon configuration. When enough measurements have been taken, an arrow showing trend (up/down) will appear. When elevation is set correctly, this value is automatically corrected.			
TEMP	Thermometer. Displays the current temperature in either C or F depending upon configuration.			

Primary Display Area Overview

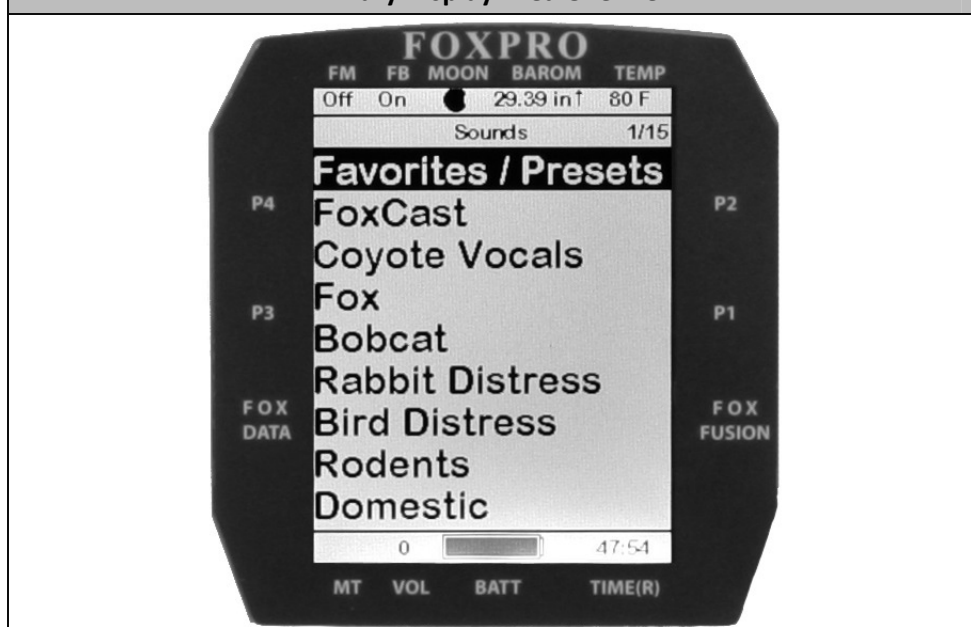

Details

The image above shows the primary display area for the Shockwave remote with default settings using the day theme. Above the menu items you will see “Categories” which is the title of this particular screen. When you enter other menu sections, the title will change accordingly. The two main items on the screen “Favorites/Presets” and “FoxCast” options are always available on this screen (in both Category and Sound List mode). Directly beneath “FoxCast” begins the category listings. If using sound list mode, you will then see “Sound List” as the third option.

Bottom Status Line Overview



Name	Details
MT	Mute status indicator. When the sound is muted, a letter M will appear. When a FOXFUSION sound is active, the M/M display may appear according to how the MUTE / Pause control has been applied. See the FOXFUSION section for more information.
VOL	Volume level indicator. Ranges 0 – 40.
BATT	Battery level indicator.
TIME(R)	Displays either stand timer or real-time clock. When an alarm is indicated, the background will blink red.

4-5 Accessing Shockwave Remote Configuration Menu

From the sounds screen, push the “Back/Menu” button a single time. This will get the Shockwave configuration menu to appear. There are a total of five elements that will appear on this menu: FOX FEATURES, Sound Settings, Display/Power, Date/Time(r), and TX1000 Settings. Each of these items is displayed below with all possible values.

FOX FEATURES Menu

This menu item provides access to turning FOX FEATURES on or off and their respective configurations.

Menu Item	Description	Values
FoxBang	Turns FOXBANG on or off.	Off, Mute, Aux, Preset 5, Preset 4, Preset 3, Preset 2, Preset 1
FoxBang Sen.	Sets FOXBANG sensitivity.	Low, Med, High

FOXMOTION	Turns FOXMOTION on or off.	Off, On
Rate	Sets the desired rate for speed of FOXMOTION.	1,2,3,4 and 5
FOXPITCH	Turns FOXPITCH on or off and sets the pitch adjustment level.	-9 through -1, off, 1 through 9
Auto Volume	Turns auto volume on or off	Off, on
USER	Allows for assigning a function to the USER button.	Theme, FOXBANG, Preset 5, FOXMOTION, Auto Volume, Time(r) Toggle, Timer Reset, Backlight
FoxGrip	Turn FoxGrip on or off.	Off, On
Button 1	Assign FoxGrip button 1 Feature.	Preset 1, Preset 2, Preset 3, Preset 4, Preset 5, Aux, Mute, FoxData
Button 2	Assign FoxGrip button 2 Feature.	Preset 1, Preset 2, Preset 3, Preset 4, Preset 5, Aux, Mute, FoxData
FoxGrip Unit ID	Displays the FoxGrip unit identification number.	
Erase FOXDATA	Enables you to erase the FOXDATA file.	N/A

Sound Settings Menu

This menu item provides access to various playback configurations, speaker configurations, and more.

Menu Item	Description	Values
Volume Step	Allows you to set the volume stepping value	1, 2, 3 and 5
Pri. Mode	Set the play mode for the primary sound.	Repeat, Juke, Single
Sec. Mode	Set the play mode for the FOXFUSION sound.	Repeat, Juke, Single
Spkr Mode	Sets the speaker mode.	Stereo, Mono, Sep Mono
Right Speaker	Turns the right speaker and right external speaker on or off	Off, on
Left Speaker	Turns the left speaker and left external speaker on or off	Off, on
Preset Mt. O/R	Preset mute override. If the sound is muted and this is set to on, the remote will un-mute the caller and start playing the preset.	Off, on

Display/Power Menu

This menu item provides access to on-screen display controls such as brightness, theme, and automatic shut off settings.

Menu Item	Description	Values
Brightness	Screen brightness control	5% - 100%
Keypad	Brightness of keypad backlight	Off – 100%
Theme	Sets the remote display theme.	FOXPRO, Day, Night
Disp Timeout	Sets the screen timeout delay.	5 seconds, 15 seconds, 30 seconds, 1 minute, 2 minutes, 5 minutes
Auto Off	Set the time delay before the remote shuts off	30 minutes, 45 minutes, 1 hour, 2 hours, 4 hours

Date / Time(r) Menu

This menu item provides access to date, time, alarm, and associated format configurations.

Menu Item	Description	Values
Stand Timer	Turns the stand timer on or off.	Off, on
Timer Reset	Resets the stand timer to 0:00	
Alarm (min)	Set the duration for the alarm.	1 minute – 60 minutes
Time	Set the current time	Hours/Minutes
Date	Set the current date	Month/Day/Year
Time Format	Set 12 or 24 hour time formats	12 Hr, 24 Hr
Date Format	Set the desired date format	m/d/y d.m.y y-m-d

TX1000 Settings Menu

This menu item provides access to other remote configurations, radio channel settings, and sound display modes.

Menu Item	Description	Values
Radio Channel	Sets the channel of radio operation. Must be the same channel as the Shockwave digital game call	0 – 15
Download List	Invokes wireless transmission of sound list	N/A
AUX	Configure auxiliary function. FOXPRO's Jack Predator Decoys require Momentary.	Momentary, Latched
View	Sets the sound view mode.	Categories, List
Temp. Units	Configure the temperature units of measurement	F, C
Barom. Units	Configure the barometer units of measurement	In, mm

Elevation	Set your elevation above sea level	0 – 19,717 ft.
About Info	Displays system information	N/A
Restore Defaults	Shockwave remote factory reset	N/A

4-6 Verifying Channel of Operation

Prior to attempting remote controlled operation, it is important that you first verify that both the Shockwave and Shockwave remote are set to operate on the same channel. If the two devices are not on the same channel, then radio communication will not be possible.

Shockwave Channel of Operation:

1. Turn on the Shockwave.
2. Access the main menu by pushing and holding the “Menu/Select” button for about 3-4 seconds.
3. Locate the menu item that says “Remote Channel” and make note of this value. You need to verify that this is the same channel as the Shockwave remote.
4. Changing this value is done by highlighting the “Remote Channel” menu item and then pushing the “Menu/Select” button. You can then cycle through the available channels (0-15) until you find the correct one (must match the remote).
5. When the proper channel is selected, push the “Menu/Select” button to lock it in.

Shockwave Remote Channel of Operation:

1. Turn on the Shockwave remote.
2. Access the main menu and select the “TX1000 Settings” menu item.
3. “Radio Channel” will be the first option. The channel will be shown to the right of the text. This needs to be the same value that is set for the Shockwave.
4. To change the channel, highlight “Radio Channel” and then push the “Play/Select” button. Then use the scroll buttons to cycle through the available channels (0-15).
5. When the proper channel is selected, push the “Play/Select” button to lock it in.

4-7 Playing Sounds with the Remote

The first operation that most users want to perform is playing sounds. There are multiple methods in which you can initiate sound playback. Before attempting to play sounds, be sure that the Shockwave and Shockwave remote both have fresh batteries installed and that both devices are powered-on.

There are two sound view mode options within the Shockwave remote; Sound List and Categories. This is configured through the TX1000 Settings item in the main menu. The method of playing a sound is identical for both modes; the way the sounds are displayed on the screen is the only difference. By default, the Shockwave remote is setup to display the sounds by categories.

To change how the sounds are displayed, access the TX1000 Settings menu and locate the menu item titled “View”. Highlight “View” and then push the “Play/Select” button a single time. Use the scroll buttons to cycle through either “Sound List” or “Categories”. When you decide which option you would prefer to use, push the “Play/Select” button to lock it in.

Default: Categories View

When the Shockwave remote is turned on, the main screen will be displayed. The first item is “Favorites/Presets” followed by “FOXCAST”. The next menu item marks the beginning of the category listings. In category list mode, your sounds will not be displayed as one long list, but rather as elements of defined categories. You can have up to 50 unique categories. Use the Scroll Buttons to browse through the available categories. Highlight the category you wish to browse and push the “Play/Select” button to enter the category. All sounds associated with that category will be displayed. Find the sound you wish to play, and then push the “Play/Select” button to begin playback of the sound. Unless you changed the volume prior to pushing “Play/Select”, the volume will start off at level 0, so you will need to increase the volume using the volume up button in order to hear it play.

Optional: Sound List Mode

When selected, this option allows you to scroll through all available sounds in a single list. The main screen will display “Favorites/Presets” and “FoxCast”, like normal, but a third option titled “Sound List” will be present. To browse the sound list, select “Sound List” from the main screen. You will then see a page that displays the first 9 sounds (000 – 008) loaded in the list. You can use the Scroll Buttons to cycle through the sounds. Once you get to the end of the current page, the proceeding lines will advance one-by-one. After highlighting the name of the sound you wish to play, you can then push the “Play/Select” button a single time to start playback of your primary sound. Unless you changed the volume prior to pushing “Play/Select”, the volume will start off at level 0, so you will need to increase the volume using the volume up button in order to hear it play.

4-8 Volume & Mute Control

The volume can be adjusted by using the “Volume Up” and “Volume Down” buttons on the keypad mid-operation, prior to selecting a sound, or even while the caller is muted. Volume ranges from 0 through 40 and the volume is increased in steps. These steps are configured through the main menu under Sound Settings. The available stepping values are 1, 2, 3, and 5. By default, the Shockwave remote is set for a volume stepping value of 2. Volume can be controlled automatically by a feature called Auto Volume.



IMPORTANT NOTE

When you mute a sound with the Shockwave remote control, the Shockwave game call display will show an “M” to the right of the onboard volume level indicator as well. If you are actively using a FOXFUSION sound, only the primary sound will display an “M” while muted whereas the Shockwave remote shows “_ /M” to

indicate the FOXFUSION sound is muted. If you perform a double-mute to simultaneously mute both sounds, the Shockwave will display an “M” while the remote shows “M/M”.

4-9 Presets / Favorites

You can store up to 50 favorites or presets in your remote control. A favorite or preset is, essentially, a shortcut to a specific sound number and volume level. These can be set through the remote control itself or authored in a text file stored in your remote control. For more information on setting up presets, see chapter 10.

From the main screen, select the Favorites/Presets option. This will display all presets available in the remote. They are listed by preset identification number, name, and volume level. Highlight the one you wish to play and then push the Play/Select button to activate. The Shockwave will immediately begin playing the established sound at the predetermined volume level.

The remote also features 4 quick-access preset buttons providing one button access to a particular sound/volume combination. These are located on the top left and right sides of your remote control marked with “P1”, “P2”, “P3” and “P4”. If the Shockwave is muted when selecting a preset, it will remain muted. You can change this configuration with the Preset Mute Override within the menu. Preset 5 can be assigned to the User button (please see chapter 5 for setting up the User button).

Favorites/Presets can be setup two different ways; through your PC or manually. To review the instructions for creating presets via your home computer, see chapter 10. To review the instructions for creating presets manually, just using the Shockwave remote, see Chapter 2.

5. FOX FEATURES

This section explores all of the available FOX FEATURES in-depth to help you understand how to use them and get the most out of your calling experience.

It is important to note that some FOX FEATURES are not compatible with other FOX FEATURES and some remote operations will override FOX FEATURES when called upon. As a result, there may be times when you try to perform an operational change with the Shockwave remote that results in a pop-up message asking you if you wish to cancel the current FOXFEATURE to enable the desired operation.



IMPORTANT NOTE

No matter what FOX FEATURE you have engaged, if you change the primary sound from one sound to another, it will automatically disengage the active FOX FEATURE. FOX FEATURES will work with some other modes of operation such as Jukebox Mode and FOXCAST, but as soon as switch to a different sound, that

feature will be turned off.

5-1 FOXFUSION

FOXFUSION allows you to fuse (combine) two individual sounds while operating your Shockwave. When you play a sound normally, as described in chapter 4, you access your sound or category list, pick the sound, and push “Play/Select”. This sound that you pick is your main or primary sound. The secondary sound (or FOXFUSION sound) is picked separately from a similar sound or category list called “FOXFUSION Sounds”. To access the “FOXFUSION Sounds” list, push the FOXFUSION button on the right side of the remote control.

Both sounds will have their own unique properties such as volume level and they can both be muted independently or together. The FOXFUSION button on the remote allows you to switch back and forth between the primary and FOXFUSION sound.

To Fuse Two Sounds:

1. Turn on the Shockwave and Shockwave remote.
2. Select a sound and volume like normal—this is the primary sound.
3. Push the “FOXFUSION” button on the right side of the Shockwave remote. The screen title changes to “FOXFUSION Sounds”.
4. Select the FOXFUSION sound in the same manner you would the primary sound and then push “Play/Select” to initiate playback. Both sounds should now be playing.

IMPORTANT NOTE

While FOXFUSION is engaged changing the primary sound results in FOXFUSION automatically shutting off. If you engage other FOX FEATURES, you may receive a warning message that FOXFUSION will be deactivated by continuing.

Tip from FOXPRO

FOXFUSION has a variety of possible uses in the field. Combining two different coyote howls provides a great effect of two coyotes in a given area talking back and forth. With the independent mute capabilities, you can create endless scenarios. Experiment with FOXFUSION before heading out on a hunt to put together a list of combinations that you would like to try utilizing and to become familiar with FOXFUSION operation. Even more; consider fusing together two stereo audio files (each plays a sound through one speaker) for effectively playing 4 sounds at one time!

Mute Operation in Conjunction with FOXFUSION

Mute operation with FOXFUSION engaged is slightly different than normal operation. When on the regular “Sounds” screen, pushing the mute button will result in both the primary sound and FOXFUSION sound being muted. The mute status indicator will display “M/M”. By switching to the FOXFUSION Sounds screen, pushing and holding the mute button for about 2-3 seconds will

result in the FOXFUSION sound being muted only. The mute status indicator will display “_/M”. To mute the primary sound, you must push and hold the mute button for about 2-3 seconds while on the regular “Sounds” screen. The screen will display “M/_”.

Actions that Won't Work with FOXFUSION

There are a number of actions that will not work while FOXFUSION is engaged. They are listed below.

- You cannot fuse presets or FOXCAST sequences—only individual sounds.

Actions that Will Deactivate FOXFUSION

By making any of the following actions, FOXFUSION will be deactivated.

- Changing of the primary sound
- Engaging other FOX FEATURES
- Pushing a preset quick access button
- FOXBANG activation
- Playback of a FOXCAST sequence

5-2 FOXMOTION

FOXMOTION is a unique feature that allows you to “move” the sound between the left and right speakers at varying rates to portray an effect of the sound (animal) moving. There are 5 different rates or speeds at which you can have FOXMOTION operate. The lower the setting, the more gradual the transition from one speaker to the other will be.

Activating FOXMOTION:

1. Turn on the Shockwave and Shockwave remote.
2. Begin sound playback like normal.
3. Access the Shockwave remote main menu and select the FOX FEATURES item.
4. Select FOXMOTION and change it to on. Then select the Rate item directly beneath it to adjust the speed that FOXMOTION operates at.

FOXMOTION will also work with external speakers. By using an external speaker with a longer cable, you can get more distance between the two sounds helping to enhance the effect even more. You cannot turn the speakers off or on with the Shockwave remote while operating with FOXMOTION.

Tip from FOXPRO

FOXMOTION can be stacked with FOXITCH to provide an incredibly unique sound playback experience. Another exciting technique is to use FOXMOTION while playing a stereo audio file to develop the effect of two animals moving around.

5-3 FOXBANG

When activated, FOXBANG reacts to the report of a firearm by automatically switching to an assigned function established within the Shockwave remote. There are 8 different settings for FOXBANG. The available functions you can link to FOXBANG activation include: FOXDATA, mute (toggles mute on/off), auxiliary (toggles auxiliary device on/off), preset 1, preset 2, preset 3, preset 4, and preset 5. When FOXBANG is triggered, it will create a new record within your FOXDATA in addition to performing the specified action.

To Activate FOXBANG and Assign a Function:

1. Access the FOX FEATURES menu on the Shockwave remote and locate FOXBANG.
2. Cycle through the available options from "Off" to the desired function you would like FOXBANG to be linked to.
3. When the desired function is selected, push the "Play/Select" button to lock it in.

As the remote control has an internal sensor that senses when your firearm has been discharged, it is important to make sure that you have the correct sensitivity level set for your particular firearm. There are 3 sensitivity levels that you can choose from: Low, Medium, and High. The lower sensitivity setting should be used with higher caliber firearms such as a .30 and higher. High sensitivity should be used for smaller calibers such as .17 to .22. Everything else should work fine with the medium setting.

Setting the Sensitivity:

1. Access the FOX FEATURES menu on the Shockwave remote and locate FOXBANG.
2. Select FOXBANG Sen. and use the scroll buttons to cycle through the available sensitivity options.
3. When the sensitivity level has been set, push "Play/Select" to lock it in.

Tip from FOXPRO

The FOXBANG sensor is located inside of the Shockwave remote. In order for it to detect the gunshot, the remote needs to be relatively close to the firearm (within 5 feet). It is assumed that most hunters will have the remote on a lanyard around their neck.

An unintended and unavoidable consequence of adjusting the FOXBANG sensitivity to the highest level is that handling noises, such as the banging of the transmitter case on your firearm stock, may cause unexpected activation of FOXBANG. For this reason, you should choose the lowest sensitivity that affords reliable activation from the muzzle blast. FOXBANG is intended to work when the transmitter is located within about 5 feet of the firearm muzzle.

Tip from FOXPRO

Before using FOXBANG in the field, head out to your local shooting range and test the different sensitivity levels to find the one best suited to your firearm.

5-4 FOXPITCH

FOXPITCH enables you to modify the pitch of a sound being played to make it sound higher or lower than the original recording to effectively transform the sound into something different. This feature can be useful in areas that you frequently call for predators. If a particular sound has netted you a good bit of success, like Lightning Jack, for example, but the animals do not respond to that sound near as much as they did before, FOXPITCH allows you to manipulate that sound to help make it *fresh* again.

FOXPITCH has numerous levels of operation. The normal state of a sound is when FOXPITCH is set to off. When increasing the pitch, the value will rise from 1 through 9. Lowering goes from -1 through -9. As you adjust the pitch value, the effect will take place immediately. Note that if you change the primary sound, FOXPITCH will automatically be deactivated.

Activating FOXPITCH:

1. Access the FOX FEATURES menu on the Shockwave remote and locate FOXPITCH.
2. Select FOXPITCH and use the scroll buttons to change the value from "Off" to the desired level.
3. When the pitch adjustment is set, push the "Play/Select" button to lock it in.

5-5 AUTO VOLUME

Different hunters like to deploy different tactics in the field. For example, some may get setup and start playing their favorite sound at a specific volume level until an animal shows up. Others prefer to have their volume level change frequently. While both methods have been proven successful, Auto Volume takes care of your volume manipulation so that you can keep focusing on the action in the field. When activated, auto volume begins playing your sound at the lowest volume setting. Over the course of a few minutes, your volume level will slowly begin to rise. Once it reaches a certain point, the volume will then begin to modulate up and down automatically.

Activating AUTO VOLUME:

1. Access the FOX FEATURES menu on the Shockwave remote and locate AUTO VOLUME.
2. Change the value from off to on.
3. After changing to on, push "Play/Select" to lock it in.

When you are operating with Auto Volume engaged, you can still adjust the volume, but the adjustment that you make is relative only to the maximum volume that Auto Volume will climb to during its operational cycle. If you change sounds while AUTO VOLUME is turned on, it will be automatically turned off.

5-6 User Button

The User button is located on the bottom left side of your Shockwave remote keypad. This button can be assigned a function of your choice for quick one button access. You can choose from preset 5, theme change, FOXBANG, FOXMOTION, Auto Volume, time(r) toggle, timer reset, or backlight.

Programming the User Button:

1. Access the FOX FEATURES menu on the Shockwave remote and locate USER.
2. Select USER and use the scroll buttons to cycle through the available options.
3. When the desired option has been set, push "Play/Select" to lock it in.

If you selected FOXMOTION as your USER button feature, please be aware that it will actually toggle the state of FOXMOTION. For example, if FOXMOTION is turned off when you push the USER button, it will automatically turn on FOXMOTION and take you straight to the configuration screen. If you have FOXMOTION on already, it will turn it off. If you change sounds, FOXMOTION will be turned off.

5-7 FOXDATA

If you enjoy keeping records of your hunts and studying the records frequently to detect trends or patterns, then FOXDATA will become an important feature for you. FOXDATA is a digital-journal, of sorts, that allows you to track details from any hunt with the intent of archiving those details for future study. At the push of a button, FOXDATA creates a new log entry documenting the current state of the remote control including: current playing sound, volume level changes, FOXFUSION usage, temperature, barometric pressure, date, time, moon phase, and timer.

The recorded data is stored in a CSV file within the remote control. You can access this file by connecting the Shockwave remote to a PC (see chapter 10). CSV files can be opened with popular software titles such as Microsoft Excel.

As an extension to FOXDATA, FOXPRO has developed an online extension that you can use to store your data. This online application will track your information for you to plot out trends, averages, and all other details. You can quickly import your FOXDATA file directly into your own account to turn the data into useful onscreen information with charts and graphs. Determine your hunt/harvest ratio, time spent in the field, and even download reports in PDF format. Visit the website below for more information on the FOXDATA online extension:

<http://www.gofoxpro.com/foxdata/>

Tip from FOXPRO

In order to make sure that your collected data is organized in a structured, per-stand basis, it

is important that you remember to start and end the FOXDATA tracking feature at the start and end of each stand. Otherwise, the data set will not be closed and you may end up with multiple stands featured as a single data set. FOXDATA will automatically record FOXBANG and FOXGRIP activations only. All other records are generated by pushing the FOXDATA button a single time.

Using FOXDATA:

1. At the beginning of a hunt, before you start calling, push and hold the FOXDATA button for 1-2 seconds. This button is located on the side of the Shockwave remote.
2. Select "Hunt Started". After selecting this option, FOXDATA recording begins. To check whether other not FOXDATA is actively recording, access the FOXDATA menu screen. The title bar will display "(R) FoxData – Comment" where the (R) is the active recording indicator.
3. Optionally, select the current weather conditions to further notate this hunt. The options are listed in a chart below.
4. Proceed forward with your hunt and use the caller just like you normally would. Each time you wish to create a log entry, push the FOXDATA button a single time and the current state will be recorded.
5. After you have completed the hunt, push the FOXDATA button for 1-2 seconds and select one of the shown options to close the session with a specific comment reflecting the outcome of the hunt.

The options for ending a hunt are outlined in the table below:

Ending Name	Description
Successful Call	Successfully called in animal, no kill-shot provided
Successful Call/Kill	Successfully called in and killed animal.
Shots Fired / Miss	Successfully called in, took shot, missed.
Camera Shot	Successfully called in, shot with camera
Nothing Seen	Nothing called in
Premature Ending	Interrupted (weather, human, other)

The options for weather conditions are outlined in the table below:

Weather	Description
Weather Clear	Clear skies or mostly clear
Weather Cloudy	Cloudy skies or mostly cloudy
Weather Overcast	Overcast conditions
Weather Rain	Rainy conditions
Weather Snow	Snowy conditions

Weather conditions may change while in the field. As a result, you can update the weather notation throughout the hunt to best reflect your observations while in the field.



IMPORTANT NOTE

A quick press and release of the FOXDATA button results in a FOXDATA record being created without prompting you for a comment. When FOXBANG and/or FOXGRIP are active and triggered, a FOXDATA record is made.



IMPORTANT NOTE

Even though FOXDATA provides weather condition selections including rain and snow, be aware that the Shockwave and Shockwave remote are not weather proof or weather resistant. Proactive measures should be taken prior to using the devices in adverse weather conditions. Placing the caller in a protective container or case rather than leaving it out in the elements will help prevent damages that are not covered under the warranty terms.



IMPORTANT NOTE

If you are performing a factory reset on the Shockwave remote, be aware that it will erase your FOXDATA file. In order to preserve the data for future use, make sure that you back up the file prior to doing a factory reset.

5-8 FOXGRIP

This provides you with the ability to setup a FOXGRIP accessory. To use the FOXGRIP accessory with your Shockwave, you must first pair the FOXGRIP device with your Shockwave remote control.

Pairing the FOXGRIP to your Shockwave Remote:

1. Make sure that your FOXGRIP has a fresh battery installed.
2. Access the FOX FEATURES menu and locate the FOXGRIP Unit ID menu option.
3. Push the "Play/Select" button a single time. A message will appear stating "Activate FOXGRIP to pair now."
4. Push the button on your FOXGRIP. The Shockwave remote will detect the signal and then display the FOXGRIP Unit ID to the right of the menu item.

After the FOXGRIP device is paired with your Shockwave remote, the next step is to determine what particular feature you would like to assign to FOXGRIP. The following options are available: FOXDATA, mute, auxiliary, preset 5, preset 4, preset 3, preset 2, and preset 1. To disable FOXGRIP, set this to off.

Assigning a feature to FOXGRIP:

1. Access the FOX FEATURES menu and locate the FOXGRIP menu item.
2. Push the "Play/Select" button and then use the scroll buttons to cycle through the available options.
3. After locating the desired option, push the "Play/Select" button to lock it in.

6. Sound Settings

The sound settings menu allows you to select how the Shockwave plays your sounds, how the speakers work, and so forth. This section will explore each of the options, their values, and how they affect operation.

6-1 Volume Step

The Shockwave remote has a range of volumes from 0 – 40. Increasing the volume in the field by increments of 1 may be too slow for some and therefore this stepping value is configurable. You can choose from 1, 2, 3, and 5. The factory default setting is 2.

Changing the Volume Step Value:

1. Access the Sound Settings menu and select “Volume Step”.
2. Use the scroll buttons to adjust the value up or down.
3. When the desired value is set, push the “Play/Select” button to lock it in.

6-2 Primary & Secondary (FOXFUSION) Mode

This setting allows you to configure how the primary and secondary (FOXFUSION) sounds will be played back through the Shockwave. There are three modes of playback: Repeat (default), Single, and Jukebox. In the default repeat mode, the sound will loop repeatedly every time it ends. In single mode, the sound will play one time and stop. In jukebox mode, once the sound has played through entirely, it will then move on to the next sound in the list.

You can mix the playback modes across the primary and secondary sounds. For example, you can have one sound repeating on the primary and then have the secondary operate in jukebox mode stepping through all of the sounds.

Changing the Primary Mode and Secondary Mode:

1. Access the Sound Settings menu and select either “Pri. Mode” or “Sec. Mode” (FOXFUSION).
2. Use the scroll buttons to cycle through the available values.
3. When the appropriate setting is displayed, push the “Play/Select” button to lock it in.

When using FOXCAST mode or presets for playback, these modes will be overridden.

6-3 Speaker Mode

There are three speaker modes available for you to select from. These modes affect how sounds are played through the speakers. The modes are: Stereo, Mono, and Sep Mon (Separate Mono).

By default, the device will be setup for stereo speaker mode. As the Shockwave has a quad speaker setup (left horn/cone and right horn/cone) a stereo audio file will be split so that the

left channel plays through the left speakers while the right channel plays through the right speakers. If you are operating with FOXFUSION with stereo sounds, the left/right channel distribution will be the same.

Mono mode results in left/right channels being condensed so that the same sounds play through all speakers at the same time. If using FOXFUSION, both sounds will play through both speakers.

Separate mono will mainly affect FOXFUSION. Your primary sound will only play through the right speakers (regardless of stereo or mono) and the secondary will only play through the left speakers.

6-4 Right and Left Speaker

This setting allows you to configure whether the speakers play simultaneously or individually. You choose to have both operating at once or one or the other. The right speaker is chained with the front external speaker and the left speaker is changed with the rear external speaker. By switching off the right speaker, you will also shut off an internal speaker connected to the right external speaker jack and vice versa for the left.

Turning Speakers Off or On:

1. Access the Sound Settings menu and select “Right Speaker” or “Left Speaker”.
2. Use the scroll buttons to cycle between on or off.
3. When the desired option is set, push the “Play/Select” button to lock it in.

6-5 Preset Mute Override

During normal operation, if the Shockwave is muted and you play a preset, the preset is queued for playback, but it cannot be heard until the caller is un-muted. Preset mute override will take care of this and eliminate the need for un-muting the call upon preset activation. It works by initially checking to see if mute is active and, if it is, un-mute the unit while playing the preset sound. This is especially important for FOXBANG operation. By having preset mute override turned on, FOXBANG activation will result in the Shockwave being un-muted if it is muted when the activation occurs.

Turning on Preset Mute Override:

1. Access the Sound Settings menu and select “Preset Mt. O/R”.
2. Use the scroll buttons to cycle between on or off.
3. When set, push the “Play/Select” button to lock it in.

7. Display / Power

The Display/Power menu allows you to control on-screen display options such as backlight, screen timeout, and the operational theme.

7-1 Brightness

This controls the brightness of the display. You can adjust the screen brightness from 5% (minimum) to 100% (maximum).

Adjusting the Brightness:

1. Access the Display/Power menu and select "Brightness"
2. Use the scroll buttons to increase or decrease the value.
3. When set to the desired brightness, push "Play/Select" to lock it in.

7-2 Keypad

This controls the intensity of the keypad back light. You can adjust the intensity from 0% - 100%.

Adjusting the Keypad Intensity:

1. Access the Display/Power menu and select "Keypad"
2. Use the scroll buttons to increase or decrease the value.
3. When set to the desired intensity, push "Play/Select" to lock it in.

Tip from FOXPRO

Night hunters should select the lowest possible setting for screen and keypad brightness for the best possible results. You may want to experiment with the various settings prior to a hunt to familiarize yourself with it and what to expect.

7-3 Theme

The Shockwave remote has three operational themes built in. These themes are designed to help optimize the appearance of the on-screen display based upon factors such as time of day. The two main themes to address this are: night and day. These themes provide the basic framework for the visual look, but you are not limited to the themes default setting. You can still adjust screen brightness to fine-tune it to your specific needs. Also included is the FOXPRO theme which is built with FOXPRO company colors (orange/black). This theme is very good for night hunting.

Changing Themes:

1. Access the Display/Power menu and select "Theme"
2. Use the scroll buttons to cycle through the available themes.
3. When set to the desired theme, push "Play/Select" to lock it in.

7-4 Display Timeout

After being idle for an established period of time, the on-screen display will go blank. The Shockwave remote will not power off completely during display timeout (see Auto Off) and is still completely usable. When the screen completes a timeout cycle, the screen can be reactivated by pushing any button on the keypad. There are five different time settings that you can use for configuring the display timeout: 5 seconds, 15 seconds, 30 seconds, 1 minute, 2 minutes, and 5 minutes.

This feature is also useful in helping to preserve and maximize your battery life. By having the screen shutoff when idle, the load on the batteries is reduced, which equates to improved run times of your batteries.

Configuring Display Timeout:

1. Access the Display/Power menu and select "Disp Timeout"
2. Use the scroll buttons to cycle through the available time spans.
3. When set to the desired time, push "Play/Select" to lock it in.



IMPORTANT NOTE

When your display times-out, you can push the power button a single time to wake it back up to ensure that no functions are initiated. For example, if you were to use a preset button or mute button in attempt to wake the remote up, you will be performing the function of that button at the same time. A single press of the power button will wake it up without causing any changes in operation.

7-5 Auto Off

After being idle for an established period of time, the Shockwave remote control will completely power down. When this happens, the remote must be powered back on like normal. There are five different time settings that you can use for configuring the auto power off: 30 minutes, 45 minutes, 1 hour, 2 hours, and 4 hours.

Configuring Auto Off:

1. Access the Display/Power menu and select "Auto Off"
2. Use the scroll buttons to cycle through the available time spans.
3. When set to the desired time, push "Play/Select" to lock it in.

8. Date / Time(r)

The Date / Time(r) menu provides access to the date and time configuration, stand timer configuration, and the stand alarm.

8-1 Stand Timer & Timer Reset

When activated, the far right indicator on the bottom status line will begin keeping time that has elapsed since the Shockwave remote has been powered on. The timer displays as: “MMM:SS” (“M” stands for minutes and “S” for seconds). The stand timer begins tracking time as soon as the Shockwave remote is turned on.

Turning on the Stand Timer:

1. Access the Date/Time(r) menu and select “Stand Timer”
2. Use the scroll buttons to change between off and on.
3. When set to the desired position, push “Play/Select” to lock it in.

Resetting the Stand Timer:

1. Access the Date/Time(r) menu and select “Timer Reset”
2. Push “Play/Select” to reset the timer.

To get the clock back on the display, simply set the stand timer to off.

8-2 Alarm

The Shockwave remote features a visual alarm that can be set to go off after a span of time. The available times are represented in minutes: 1 – 60. When the alarm is set and the configured time span passes, the stand timer (or clock if set to display the clock) will begin to flash alerting you.



IMPORTANT NOTE

The alarm is based upon the stand timer only, not the real time clock. Keep in mind that the stand timer begins tracking time as soon as the Shockwave remote is turned on. Make sure that you select the **Stand Timer Reset** option (described earlier on this page) when setting up the alarm. For example, if you turn on the Shockwave remote and 10 minutes have passed while getting setup, and then you set the alarm for 30 minutes, it’s going to go off 20 minutes later unless you use the Stand Timer Reset prior after setting the alarm. Also, if the screen timeout occurs prior to the alarm going off, it will turn back on when the alarm goes off.

Setting the Alarm:

1. Access the Date/Time(r) menu and select “Alarm”
2. Use the scroll buttons to select the desired amount of time in minutes. To shut off the alarm, simply change the value to off.
3. Push “Play/Select” to set the alarm.

8-3 Time

The Shockwave remote has a real time clock. This clock must be set when you first install or change batteries.

Setting the Clock:

1. Access the Date/Time(r) menu and select “Time”
2. Use the scroll buttons to set the current time.
3. Push “Play/Select” to lock it in.

The clock can be displayed in either the standard 12 hour format or 24 hour format (military time).

Configuring Time Format:

1. Access the Date/Time(r) menu and select “Time Format”
2. Use the scroll buttons to select either 12 or 24 hour time format.
3. Push “Play/Select” to lock in the setting.

The bottom status line of the Shockwave display can show either the current time or the stand timer. The stand timer will only be displayed if it is turned on—otherwise, the clock will show the current time.

8-4 Date & Date Format

The Shockwave remote will keep track of the current date in order to proper render moon phases. This needs be setup when you first start using the Shockwave remote.



IMPORTANT NOTE

The Shockwave remote control features a moon phase indicator. In order to display the correct moon phase, it is imperative that you enter the correct date. Otherwise, the displayed information may not be correct.

Setting the Date:

1. Access the Date/Time(r) menu and select “Date”
2. By default, the first option is the month. Use the scroll buttons to select the current month and then push the “Play/Select” button.
3. Next you set the day using the same method described above, and then push “Play/Select”.
4. Finally, set the year and push “Play/Select” to lock it in.

There are three different date formats that you can choose from depending upon your personal preference. They are month/day/year, year-month-day, and day.month.year.

Configuring Date Format:

1. Access the Date/Time(r) menu and select “Date Format”
2. Use the scroll buttons to cycle through the options.

3. When your desired date format is shown, push “Play/Select” to lock it in.

9. TX1000 Settings

The TX1000 Settings menu allows you to change the radio channel, download the sound list, and configure other options.

9-1 Radio Channel

The Shockwave remote can be configured to operate on one of 16 different radio channels (0-15). If you change the radio channel for the Shockwave remote, you must also change the radio channel for the Shockwave digital game call—otherwise the two devices will not be able to communicate.

Changing the Radio Channel:

1. Access the TX1000 Settings menu and select “Radio Channel”
2. Cycle through the available channels using the scroll buttons.
3. When the proper channel is set, push the “Play/Select” button to lock it in.



IMPORTANT NOTE

Do not change the radio channel on the remote control without also changing it on the Shockwave. Doing this will result in a loss of communication. To change the channel on the Shockwave, please see chapter 3.

9-2 Download List

Any time you reprogram the Shockwave digital game call to add new sounds or new FOXCAST sequence files, you must download a new copy of the play list to the Shockwave remote. This menu item will guide you through that process. The entire programming process is covered in more detail later in the manual.

9-3 AUX

The auxiliary jack operation specifications can be changed for either momentary or latched. All FOXPRO Jack Predator Decoys require that the jack be setup for momentary.

Configuring the Auxiliary Setting:

1. Access the TX1000 Settings menu and select “AUX”.
2. Cycle through the two options using the scroll buttons.
3. When the appropriate setting is selected, push the “Play/Select” button to lock it in.



IMPORTANT NOTE

Some third party decoys may require latched operation as opposed to momentary. A detailed list of other products and their specific requirements is not maintained

by FOXPRO. You will need to check with the equipment manufacturer to determine if it is compatible and what the requirements are.

9-4 View

The Shockwave remote control can display your sounds either by general listing or by category listing. Sound categories are the best route to go if you have a large number of sounds.

Configuring Sounds View:

1. Access the TX1000 Settings menu and select "View".
2. Cycle through the two options using the scroll buttons.
3. When the appropriate setting is selected, push the "Play/Select" button to lock it in.

9-5 Temperature Units

The integrated thermometer can display temperature in either Celsius or Fahrenheit based upon your preference.

Configuring the Temperature Units:

1. Access the TX1000 Settings menu and select "Temp Units".
2. Cycle through the two options using the scroll buttons.
3. When the appropriate setting is selected, push the "Play/Select" button to lock it in.

9-6 Barometer Measurement Units

The Shockwave remote can display barometric pressure readings in either inches or millimeters depending upon your preference.

Configuring the Barometer Measurement Units:

1. Access the TX1000 Settings menu and select "Barom Units".
2. Cycle through the two options using the scroll buttons.
3. When the appropriate setting is selected, push the "Play/Select" button to lock it in.

9-7 Elevation

Barometric pressure is the reading provided by a barometer in measuring atmospheric air pressure. The pressure is not constant, but changes depending upon altitude and weather conditions. In order to get the most accurate measurement with your Shockwave remote, it is recommended that you set the elevation value for your location. Atmospheric pressure is the greatest at sea level as compared to higher altitudes. To get the best calculation, knowing your approximate elevation will greatly increase the accuracy.

Setting the Elevation:

1. Access the TX1000 Settings menu and select "Elevation".
2. Cycle through the options until you find the closest match for your location.

3. When the appropriate value is displayed, push the “Play/Select” button to lock it in.

There are many online resources that can assist you in determining your elevation above sea level. Performing an online search will provide you with ample results featuring maps or other tools to determine the elevation for your particular area.

9-8 About Info

The About Info screen displays a variety of information pertaining to version number, number of sounds loaded, number of FOXCAST sequences loaded, number of categories loaded, and the number of presets.

9-9 Restore Defaults

To reset your Shockwave remote control back to factory defaults, use this option. Please be aware that restoring factory defaults will result in loss of your presets/favorites, sound list, categories, and all FOXDATA information.

Restoring Factory Defaults:

1. Access the TX1000 Settings menu and select “Restore Defaults”.
2. A confirmation screen is displayed asking you if you are sure. To proceed, select “Yes”, otherwise, “No” will return you to the menu.
3. Once the reset is complete, the remote will be back to factory default conditions.

10. Shockwave Remote USB Operation

The Shockwave remote control features a mini USB port located inside of the battery compartment, just above the batteries. In order to connect the remote to a computer, you will need to obtain a mini USB type A/B cable (provided with the Shockwave).



IMPORTANT NOTE

Before connecting the Shockwave remote to a computer, be sure that it has fresh batteries installed. The Shockwave remote must be powered on while connected to a computer. If the device loses power while connected to a computer during a write-mode, there is a possibility of corruption of the file system. **Make sure the batteries are fresh** to prevent any damage from occurring.

Connecting the Shockwave Remote to a Computer:

1. Connect the USB cable from the jack on the Shockwave remote to a USB port in the computer.
2. Power on the Shockwave remote. The screen should activate and show “USB Active” instead of the sound screen.

3. Your operating system will then detect the device and take the necessary steps to make it accessible for you. Windows users will see a new drive appear named "TX1000". Mac users will see a new icon appear on their desktop called "TX1000".



IMPORTANT NOTE

Depending upon your computer setup and operating system, the exact details of what will happen when you connect the device may vary slightly. In general, the operating system will detect that a piece of hardware has been detected. From there, you should receive some sort of visual or audible notification that something has been plugged in.

When the Shockwave remote is connected to a computer, you can browse through the device just as you would any other USB storage device. Inside of the file system, you should encounter two files. These files are:

File Name	Description
foxdata.csv	Contains the harvested FOXDATA data.
presets.txt	Contains the list of presets.

Each of these files can be viewed on most operating systems through the standard plaintext editor such as notepad. With the exception of the FOXDATA file, the other files can be modified for your specific configurations.

10-1 Editing the Presets File

While you can create and edit your presets through this file, it is recommended that presets be created through the Shockwave remote as described in chapter 2. Open the file titled 'presets.txt' to view the contents. The file should look something similar to the following:

Example 'presets.txt' File
007,31
086,23
090,40
007,07
001,40
067,40
005,40
003,23

Each line in this file is referencing a specific sound number and a volume level separated by a comma. The first line of the example shown above indicates sound number 007 established for playback at volume level 31. You can add more presets to the file manually by editing it through your computer. Once you have it edited to your liking, save the file and close it.

10-2 Viewing the FOXDATA File

The FOXDATA file is in what is called CSV format or comma separated values. In a CSV file, the first row defines the variable (field) names each separated by a comma and subsequent rows contain relative data for those defined fields. At first glance, the file may seem confusing and not very useful. FOXPRO has developed an online FOXDATA extension that allows you to create an account on our website, upload your 'foxdata.csv' file and have that file turned into easy-to-read charts, graphs, and tables.

Let's say you have 3 months of hunts recorded in your Shockwave remote through FOXDATA. You can login to your account, upload the file, and then the system will take care of the rest. You can then erase the current FOXDATA file from the Shockwave remote to start recording again. 3 months later you can upload another copy of the file to track the next batch.

The CSV file can be opened for viewing through a program such as Microsoft Excel. The field titles will be displayed and the relative data will be displayed in rows beneath that. While Excel can provide you with a quick glance at the information, turning it into something useful is where the FOXDATA online extension comes into play.

Be sure to check out the FOXDATA online extension online at:

<http://www.gofoxpro.com/foxdata>

11. Programming the Shockwave

The FOXPRO Shockwave digital game call can be completely programmed from home with the use of a computer. It is possible to reprogram a Shockwave from a Windows based PC as well as a Mac. Both subjects will be covered in this section.

The Shockwave can play a number of different audio file types. This includes FOXPRO's proprietary FXP and 24B files, MP3 files, uncompressed WAV files, and FLAC files. If you are using your own audio files, make sure it is an MP3, uncompressed WAV, or FLAC file, otherwise it will not work.

11-1 Requirements

The Shockwave digital game call features a mini USB port located on the front. You will need to obtain an appropriate mini USB type A/B cable. The same cable can be used to connect your Shockwave remote to your computer as well.

You will need a computer with an available USB port to connect to. It is not recommended that you connect to a USB hub, but rather to a USB port directly on your computer.

You will need an online connection. FOXPRO sounds and software are distributed online from the FOXPRO website. In order to access the sounds and software, an online connection is required.

11-2 Connecting to a Computer

Be sure to check which version of the Shockwave you have so that you can follow the appropriate steps in connecting the device to your computer. To determine which version you have, turn on the Shockwave and watch the screen closely. The version number is briefly displayed towards the bottom of the screen. After determining your version, refer to the instructions below.

Version 1.5 and Newer:

1. Make sure the Shockwave is turned off.
2. Locate the USB port on the front of the Shockwave and connect one end of the USB cable to this jack.
3. Connect the other end of the USB cable to a jack on the computer.
4. Your computer may provide an audible or visual alert that a new device has been connected.

Version 1.4 and Older:

1. Turn on the Shockwave.
2. Locate the USB port on the front of the Shockwave and connect one end of the USB cable to this jack.
3. Connect the other end of the USB cable to a jack on the computer.
4. Your computer may provide an audible or visual alert that a new device has been connected.

Windows Users

After the Shockwave has been connected to your computer, there are a number of things that can happen. First, Windows users may see a “Found New Hardware” notification or even hear an audible tone indicating a USB device has been connected. The first thing to determine is what drive letter the Shockwave is being assigned to. To do this, you can click on the Windows start button and then click on ‘Computer’. The next screen will show all of the available drives on this computer. Look for one titled “SHCKWV1”. Beneath this icon is a letter in parenthesis—make a note of this letter as this is what drive letter the Shockwave is on. Double-click on this icon to view the files.

Mac Users

After the Shockwave has been connected to your computer, you may hear an audible tone or even get a visual alert indicating that a device has been connected. Once detection is complete,

you should see a new icon appear right on your desktop that is titled "SHCKWV1". Double-click on this icon to view the files.

11-3 Manual Programming Process

Manually programming the Shockwave is a very simple process. You can perform the process from a Windows PC or a Mac without any special software. The only requirements are that you have the appropriate USB cable, fresh batteries, and a USB port on your computer.

To begin, connect the Shockwave to your computer as described earlier in this chapter. Once it is connected, browse to the Shockwave and open it to view the contents. You should notice a folder inside the Shockwave titled "Sounds". This folder is the location in which all of the sounds, sequence files, and category files must be stored. If you wish to add new sounds, simply place the sound files directly inside of the "Sounds" folder. Sounds can be removed by either deleting them from the "Sounds" folder or moving them to a folder on your hard drive for later use.

It is not required that you rename the sound files in any way to correlate with a specific position within the sound list, but doing so can help make the task of creating sequences and category files much simpler. The next section of the manual discusses file indexing. The files are sorted based upon the individual names of the sound files. For example, a sound file labeled "Aggressive Bobcat" would appear before a sound labeled "Bobcat in Heat".

After placing the sound files into the Shockwave "Sounds" folder, you must disconnect the Shockwave from your computer and then synchronize the Shockwave remote control with the Shockwave to update the sound list. Instructions on updating the Shockwave remote sound list are featured later in this chapter.

11-4 Indexing the Files

Files stored in the Shockwave and Shockwave remote are sorted based upon the names of the files. For example, a sound titled "000 My Sound" will appear in the list before a sound titled "123 Lightning Jack". While you can simply copy and paste sounds directly into the Shockwave's sound folder, the ultimate order in which those sounds will appear in is based upon the names of those files. This is important to understand when considering the implications upon other features such as FOXCAST.

The Shockwave can hold up to 1,000 sounds in total. Proper indexing values for all file names range from 000 through 999. If you download a 4 sound pack from FOXPRO, you will see the files in a format similar to:

Example 4 Sound Pack File List
B00 Raspy Woodpecker
B51 Raven Duet
C26 Coyote Pair

Each one of those files contains the FOXPRO sound library identification number as the first part of the file name. Obviously, the sound library identification number does not fall within the 000 through 999 indexing values. This means that if you wish to assign a specific position for any of those files, those numbers must be replaced by a proper index value. Using your computer, you can easily rename those files to become something similar to:

Example 4 Sound Pack File List
100 Raspy Woodpecker
101 Raven Duet
102 Coyote Pair
103 Raccoon Fight

By renaming the files, they will now have an index value to assign their individual positions within the sound list. When building a FOXCAST sequence, for example, referencing sound "100" will link to "Raspy Woodpecker". While indexing is not required, it can certainly be useful in many occasions.

11-5 Using the FOXPRO Programming Utility

The FOXPRO Sound Programming Utility for Windows based PC's can be downloaded from our website at the following link:

<http://www.gofoxpro.com/programming/>

Locate the "Software Links" heading and select the "FOXPRO Programming Utility" link. When the page is loaded, locate the "Product Information" box. This box displays current version number, publication date, and MD5 and SHA1 information for validating the installation file as being genuine. The last item in the box contains the official download link. To begin the download, click on the "Download" button.

If you are upgrading from a previous version of the FOXPRO Programming Utility, there is no need to uninstall the original version before launching the new installer as it will automatically upgrade for you. Your original sound library storage folder will remain unchanged.

Depending upon what internet browser you are using, you may be prompted to "Open", "Run", or "Save" the file that is being requested. Some browsers may not prompt you for action and just save the file to your default Download folder. If you are presented the option, we recommend selecting either "Open" or "Run"—in doing this, the installer will automatically launch when the file has been downloaded. Otherwise, you will need to browse your Download folder for the install file which is titled: "foxpro-programming-utility-installer.exe". You will then need to open the file to launch the installer. The installation is very brief and straightforward. When the installation is complete, a message of success will display on the screen.

Launching the Utility

The installer creates a shortcut to launch the programming utility through your programs menu under the Windows start button. The location is: Start Button -> All Programs -> FOXPRO -> FOXPRO Programmer Click on the "FOXPRO Programmer" icon to launch the utility. Upon successful launch, you will be presented with the main interface.

Connecting your Shockwave to the PC

Connect the Shockwave to your PC as outlined in section 11-2.

After connecting your FOXPRO game call to your PC, the utility should recognize the device as being a valid product and display "Connected to..." followed by the device name. The "Caller Sound Files" column should become active and display the sounds currently installed.

File Locations / Sound Library

If you had the previous version of the utility installed, your default sound library storage point is located at "C:\FOXPRO\Sounds". By clicking on the "Browse Library" button you can browse the sound files stored at that location.

If this is a fresh install with no previous versions, your default sound library storage point is located under your Documents (or My Documents) folder\FOXPRO\Sounds. By clicking on the "Browse Library" button, you can browse the sounds stored at that location.

Your sound library will probably be empty by default. You need to obtain sounds and place them into your library folder in order to install them into your FOXPRO game call.

1. Connect your FOXPRO device to your PC
2. Launch the programming utility
3. If you do not see your new sounds under the "Source Sound Files" column, use the "Browse Library" button to navigate to the correct location. When the appropriate files are found, double-click on any of the sounds to automatically load all files from that location.
4. Select one, multiple, or all sound files in the "Source Sound Files" column. Click on the position you wish to load the sounds into and click "Insert". Or if you are replacing existing sounds, use "Overwrite".
5. When complete, click on the "Update Caller" button to save your changes. Any sounds being removed will automatically be backed-up.
6. Exit the utility and update your remote control as per the instructions in the next section.

11-6 Editing the Categories Manually

Shockwave sound categories are maintained and defined through a text file that is located in the Shockwave. To begin working with the categories, open the file titled 'categories.txt' (located inside of the "Sounds" folder). The file should look something similar to the following:

Example 'categories.txt' File

```
Coyote Vocals
000
001
```



```
002
003
004
Fox Vocals
023
024
025
026
Whitetail Sounds
078
079
```

The above example shows the category layout for three categories: Coyote Vocals, Fox Vocals, and Whitetail Sounds. The sounds listed beneath each category name are the sounds that comprise that category.

Through simple editing of this file, you can easily build your own category names and associated sound lists. The best way to go about doing this is to have your Shockwave remote control next to you. Turn it on and access the sound list. Next to each one of the sounds is a three digit number. This number is prefixed to the sound name by the Shockwave remote. Let's say you want to create a raccoon category. Look through your sound list and find your raccoon sounds. For this example, let's say that you encounter 5 raccoon sounds in your sound list on sounds 090 – 094. Open the 'categories.txt' file and add the following:

Example 'categories.txt' File

```
Raccoon Sounds
090
091
092
093
094
```

Save the file and exit. You have now successfully created your very first sound category. As you can see, the process is very simple to do. The first line is the name of the category which appears in plaintext. Beneath that category name you list the sounds numerically based upon their assignment within the Shockwave remote control.

Any time you modify the category file in the Shockwave, you must download the playlist to the Shockwave remote control.

11-7 Editing the Categories with FOXPRO Utility

Make sure that you have installed the FOXPRO Sound Programming Utility as described in section 11-5. When working with the Shockwave and the utility, you will notice the "Edit

Categories” button above the “Caller Sound Files” column. Click on this button to launch the category editor.

The screen provides a split-screen view. The left pane shows all of the sounds installed in your Shockwave. The right pane shows all of the categories (or no categories if none have been defined). To create a new category, click on the “New Category” button, type in the desired name, then click “OK”. The new category will appear on the right.

To move sounds into a specific category, click and drag the desired sound from the list on the left into the category on the right. Note that when you are dragging the sound, the mouse pointer will turn into a speaker. When you are finished assigning sounds into categories, click on the “Save/Done” button to exit. Be sure to update the playlist on the remote control as described in section 11-8.

11-8 Updating the Remote Playlist

Before carrying out the steps listed below, make sure that you have fresh batteries in your Shockwave and Shockwave remote control. **Disconnect all accessories (speakers, decoys, USB cables, etc.) prior to starting this process.**

1. Turn on the Shockwave and Shockwave remote control.
2. Access the main menu on the Shockwave remote.
3. Select the “TX1000 Settings” menu.
4. Select the “Download Sound List” item from the menu to initiate the transfer.

Once the process is complete, you will see an overview on the screen showing you how many sounds, sequences, and categories have been detected during the transfer process. Exit the menu and return to your sound list to review the changes you have made.

If there were any problems during the transfer, the Shockwave remote will revert back to the previous sound list as a failsafe.



IMPORTANT NOTE

Verify that the Shockwave and Shockwave remote are set to operate on the same channel prior to updating the sound list. If they are not on the same channel, you will have difficulty in getting the list to update.

12. Creating FOXCAST Sequence Files

This section will provide you with detailed information on creating and installing FOXCAST sequence files in your Shockwave digital game caller.

12-1 Creating FOXCAST Sequences Manually

This process requires some basic computer operations experience. If you are not very experienced with computers, it is recommended that you seek help prior to performing any of the following steps.

A FOXCAST sequence file is a simple text based file that contains unique instructions to guide your Shockwave through a stand. These instructions include commands to change the sound, change the volume level, enter a passage of silence, and so forth. Here is a chart showing all of the various command possibilities:

Instruction	Value	Description
S	0 – 999	Denotes numerical value of sound on unit
V	0 – 40	Denotes numerical value of volume level
P	1 - 99999	Denotes pause value in seconds (approx.)
B	0-19	FOXPITCH activation and parameter
M	0 – 4	FOXMOTION and speed parameter
D	1 or 0	1= activate decoy, 0= deactivate decoy
J	n/a	Denotes Jukebox Mode for this FOXCAST File
R	n/a	Denotes Repeat Mode for this FOXCAST File
Q	n/a	Denotes Single Play Mode for this FOXCAST File

A typical FOXCAST sequence file may look something similar to the following example:

Example FOXCAST Sequence File Layout
V 20 S 15 4 P 90 V 35 S 22 V 30 S 20 3 Q

The above example is interpreted as follows:

Set volume to level 20. Play sound number 15 a total of 4 times Pause for 90 seconds. Adjust volume to level 35. Play sound number 22. Adjust volume to level 30. Play sound number 20 a total of 3 times. Quit.

Notice that you can specify how many times you wish a particular sound to be played. By entering your instruction as "S 20 3", you are thereby instructing the unit to play sound 20 a total of three times.

A FOXCAST sequence must always begin with a volume or pause. Without defining a volume level, the caller will default to volume level 0. A FOXCAST sequence file must always end with a specific ending statement. "J" represents jukebox mode. When you end a sequence with "J",

once the sequence has played through a single time, it will automatically begin playing the next FOXAST sequence. “Q” represents quit. Once the sequence has played entirely, the Shockwave will go silent. “R” represents repeat. Once the sequence has played entirely, the Shockwave will play that sequence again until it is interrupted by the operator.

The Shockwave can accept up to 20 FOXCAST sequence files. These files will need to be in a format such as:

Example FOXCAST Sequence File Names
S00 My Coyote Sequence 1.seq
S01 My Bobcat Sequence.seq
S02 Mountain Lion Calls.seq

Each file can be broken down into two parts. The first part, “S01 My Coyote Sequence”, describes the title or name of this particular sequence. The second part, “.seq”, is the file extension that defines this file as a FOXCAST sequence file. Note that the .seq file extension is not native to any operating system. This is a unique file extension for FOXPRO game calls with FOXCAST. A FOXCAST sequence file may appear as an unknown file type and display on your computer as “unknown” or “unassociated” icon.

On a Windows based PC, using a piece of software such as Notepad is all that you will need to successfully build a sequence file. Mac users would use something such as Textedit, which is a standard application.



IMPORTANT NOTE

FOXCAST sequence files are expected to run for long durations. It may be necessary to turn off the Auto Shutdown feature on the Shockwave to prevent any interruptions.

12-2 Enabling File Extensions in Windows

The Windows operating system may hide file extensions preventing you from making changes to them. For example, instead of seeing “My Coyote Sequence1.seq”, the file may read as “My Coyote Sequence1”. In order to change the file extension, you may need to configure your operating system to display file extensions. Specific details on this process go beyond the scope of this manual. You can perform an online search or consult a local computer technician for assistance with this.

12-3 Placing Sequences in the Shockwave

The Shockwave expects to find FOXCAST sequence files inside of the “Sounds” folder in the Shockwave. If you are loading the sequence files manually, the first step is to connect the Shockwave to your computer. Browse to the Shockwave and open it up. Locate the “Sounds” folder. Copy your sequence files from wherever they are stored on your hard drive, into this folder (drag and drop). If you are using the online FOXCAST file generator, you can save the file directly from the website right into the “Sounds” folder in the Shockwave.

12-4 Creating FOXCAST Sequences Online

A second, simpler option for creating sequences can be found on the FOXPRO website. The following address will direct you to the FOXPRO Online FOXCAST Sequence File Generator:

<http://www.gofoxpro.com/foxcast>

This easy to use site allows you to quickly assemble and download FOXCAST sequence files to your computer or directly to your FOXPRO game call. The site has plenty of instructions to help get you started. Just remember to save the sequence files into the “Sounds” folder in the Shockwave.

12-5 Synchronizing the Shockwave Remote

Before you can access your FOXCAST sequence files on the Shockwave remote, you must download a new copy of the sound list. To perform this, please see chapter 11 in the section “Updating the Shockwave Remote Sound List”.

13. Firmware Updates

The Shockwave digital game call and Shockwave remote both feature the ability to have firmware updates installed from home. It is crucial to determine which version of game call and remote you have prior to performing any of the update procedures.

13-1 Shockwave Digital Game Call (V1.5 and higher)

The Shockwave digital game call features a mini USB port. Make sure you have the appropriate mini USB type A/B cable for connecting the Shockwave to a PC. This same cable can be used to connect the Shockwave TX1000 remote to your PC as well.

Shockwave digital game call versions 1.5 and higher do not require specific software to perform the update. Therefore, the update can be performed on virtually any modern computer with the appropriate USB port and an online connection.

The FOXPRO firmware updates are found at the following link:

<http://www.gofoxpro.com/fwupdate>

Ample instructions will be present on the site to help ensure that you obtain the latest version for your particular device. You are welcome to contact FOXPRO technical support for assistance in this matter.

After you obtain the update file, make sure the Shockwave is turned off and then connect it to your computer. **Be advised, the Shockwave must remain turned off the entire time it is**

connected to your computer. Your computer may provide an audible or visual alert that a new device has been connected. Once it is detected, proceed with the steps below.

1. Locate the update file that you downloaded from the FOXPRO website.
2. Copy the update file from wherever it is stored on your hard drive directly into the Shockwave. Note: the Shockwave features a folder called 'Sounds'. Do not place the update file in this folder. Copy the file directly into the root of the Shockwave.
3. After the file has been copied into the Shockwave, safely disconnect the Shockwave from your computer.
4. Make sure that you have fresh batteries in the Shockwave and then turn it on. When the Shockwave is turned on, it will find the update file that you placed inside and the firmware update will occur automatically.

13-2 Shockwave TX1000 Remote

The Shockwave TX1000 remote features a mini USB port. Make sure you have the appropriate mini USB type A/B cable for connecting the remote to your PC.

The update software is only compatible with PC's running Microsoft Windows XP and newer. You can download the installation program from the following link:

<http://www.godoxpro.com/fwupdate>

Ample instructions are present on the website to aid you in the update process. You are welcome to contact FOXPRO technical support for assistance in this matter.

Begin by verifying the batteries in your FOXPRO TX1000 remote are fresh or fully charged. It is crucial that the batteries are fresh or fully charged prior to starting this process. If the batteries are weak and cause the device to lose power during the update process, the device could be damaged to an extent where it is no longer usable. Again, **make sure your batteries are fresh or fully charged** and then follow the instructions below:

1. Turn off the TX1000.
2. Open the update utility software.
3. Push and hold the user button on the bottom left of the remote. While holding in the user button, turn the remote on. You will observe a screen displaying: "FOXPRO TX1000 FIRMWARE UPGRADE CONNECT USB CABLE START UPGRADE UTILITY".
4. Connect the USB cable from the TX1000 to the computer.
5. Push the 'Connect' button on the utility to start the update.
6. When complete, disconnect the TX1000 from the computer and turn it on. You should now see the new firmware version number.

14. Product Care & Maintenance

In order to help get years of trouble free service with your FOXPRO game call, it is strongly recommended that you read and understand the following points. Many of these are considered proactive or preventative.

Avoid exposure to all precipitation and moisture. Whether you are storing your FOXPRO game call or decoy away for the summer or just having some down time from calling, it is highly recommended that you thoroughly inspect the unit for any signs of moisture. Moisture (perhaps from rain, snow, condensation, or other) can potentially enter the unit or the battery compartment and cause some serious problems. Proper care should be taken to mitigate the introduction of (or potential for introduction of) moisture into the machine and make sure that no moisture is present during storage. Moisture can quickly lead to corrosion, electrical shorts, and even rust—all of which can possibly render the unit damaged and out of warranty. This type of damage is preventable. For example, if you are operating in rainy, wet conditions, it is recommended that you place the unit inside of a large plastic freezer storage bag or use a water/weatherproof deployment bag to keep water from getting to it. When storing the unit for prolonged periods, be sure that you keep it in a dry location not susceptible to drawing moisture.

Remove batteries prior to storage or extended periods of inactivity! All batteries, whether alkaline or rechargeable, should be removed from the game calls, decoys, and remote controls prior to storage or periods of inactivity. Batteries that are left inside of electronic devices can leak over time as the chemicals start to break down. Damages caused by this can be very severe and potentially destroy the electrical components. To prevent this from happening, simply remove all batteries from all devices before you put them away. Keep in mind; damage caused by battery leakage is not a warranty issue.

Periodically charge your rechargeable batteries when not in use! Rechargeable batteries will not last forever. To help maximize the overall life of your rechargeable batteries, we recommend that you periodically charge them up, perhaps once a month or once every other month, to keep them fresh. Batteries that are left uncharged can enter into a state of deep discharge. Batteries in this state can, at times, no longer accept a charge and result in unexpected operation or complete failure in the field. It is also recommended that you replace rechargeable batteries about once a year just to keep them fresh.

Keep it clean! Our products are designed to be used outdoors and as a result, they can get dirty from time to time. While the dirt may add a bit of character and show that you use it frequently and hard, it is recommended that you spend a few moments after each hunt or at the end of the season prior to storage to clean it up a bit. Total disassembly won't be required, just remove any debris, sticks, leaves, dirt, or anything else that shouldn't be there. If dirt or foreign objects make their way into the machine, it can cause problems down the road.

Store in a dry location! If you are planning on storing the unit away for the summer, it is recommended to keep the unit in a dry location that is not prone to drawing moisture. It is also recommended to remove all batteries prior to storage.

Other storage recommendations include: Do not stack heavy objects on top of your carrying cases or other items that may be holding your caller and/or remote control. If too much pressure is applied to the remote's LCD screen, it can be punctured or damaged. Too much weight bearing down on the caller or remote could result in cracking or fracturing of the plastic housings.

Check it out before heading into the field! If you are getting your caller out for the first time this season, take it out back and check it out before you head out on a hunt. Check your remote range, fidelity, high volume, low volume, battery life, etc. Being prepared and ensuring proper functionality before heading out on a trip can help you decide if you need new batteries, if it needs service, or if everything is working well. This can help prevent cancellation of trips and potential disappointment.

15. Troubleshooting

This section covers the troubleshooting aspects for the Shockwave and Shockwave remote control. The most common problems are battery related. Before performing anything else, try installing fresh batteries. When your batteries get low, in either the Shockwave or the Shockwave remote, unexpected operation can occur. You can experience such things as loss of audio quality, loss of remote control range, and other abnormal results.

Problem	Solution
Shockwave will Not Turn On	Make sure that you have fresh batteries installed. If you are using rechargeable batteries, make sure they are fully charged. Inspect your battery tray and make sure the springs are not compressed or corroded as this could lead to poor battery connectivity. Also check all positive contacts on the tray for signs of corrosion.
Shockwave does not produce any sound	Check that the speakers are not turned off in the Shockwave remote control. Check to see if you can play sounds manually (without the remote). If you cannot play sounds manually, connect the Shockwave to a computer and inspect the sound files for missing files or signs of corruption.
Shockwave remote not controlling Shockwave	Make sure that the remote and caller are set to the same channel of operation. Then turn off the caller and remote, wait a few moments, turn them back on and try operating again.
Cannot transfer sound list to Shockwave remote	Make sure that the remote and caller are set to the same channel of operation. Keep the remote control in close

	proximity to the Shockwave caller.
Shockwave remote does not turn on	Try replacing the batteries.
Shockwave remote stuck on start-up screen	Try replacing the batteries.
External speaker does not play	If you have the speaker connected to the right external speaker jack, make sure that the right speaker is not disabled in the Shockwave remote, and vice versa with the left speaker jack. The external jacks are linked left/right accordingly.
Cannot control external decoy	If you are using a FOXPRO Jack Predator Decoy, make sure that the AUX configuration is set to momentary and not latched. If you are using a third party decoy, try using the latched setting instead of momentary.
Having trouble with programming new sounds	Check out FOXPRO's website for detailed programming information for your Shockwave. Solutions for many common issues can be found there.
Poor battery life in extreme cold weather conditions	Cold weather operations can take a serious toll on alkaline batteries. It is strongly recommended that you use lithium or rechargeable NiMH batteries to get the best performance in cold weather.
Shockwave remote will not turn on after firmware update	Contact FOXPRO technical support.
Shockwave will not turn on after firmware update	Contact FOXPRO technical support.
Cannot control volume on Shockwave	Check your Shockwave remote configuration to see if Auto Volume is activated. If it is, it would seem like you have no volume control ability.

16. Maximizing Remote Range

Remote range can be affected by many factors. Some of these factors can be controlled while others cannot. In order to achieve the best possible remote range with your Shockwave digital game call system, it is recommended that the following points be observed:

- Always use high quality alkaline or lithium cell batteries in the remote.
- Always maintain clear line of sight between the remote control and the Shockwave. Any obstructions—no matter how significant or insignificant—can adversely affect the radio signal.
- Try to keep the remote control approximately six inches away from your body, gun barrel, and metal shooting sticks as these things can detune the remote control.
- Hold the remote control vertically with the antenna pointing skyward.
- Avoid using the device remotely when you are near power lines, cellular phone towers, and radar (such as near airports or military installations).

- Try to elevate the caller off of the ground by approximately three feet. This can greatly maximize your overall remote control range. Achieving this can be done by use of the integrated tripod mount located on the bottom of the Shockwave.
- Try to avoid situations where the Shockwave is placed at a lower elevation than the remote control—the caller should always be higher.
- If you are using the Shockwave remotely from a long distance, be sure to allow enough time for device reaction before sending multiple signals. For example, if you request a sound change, consider the amount of time from radio transmission from the remote to the Shockwave until that signal is turned into a change in operation that you are able to perceive. It will not always be instantaneous and may take a second or two before a change in operation is detected from your vantage point. Mashing down button after button can get the device into a state of confusion which could result in undesirable results.
- If you are operating around another Shockwave user, make sure that you are both on different channels to prevent any interference.

17. FCC & IC Information

FCC Information

NOTE: This equipment has been tested and found to comply with the limits for a Class B digital device, pursuant to Part 15 of the FCC Rules. These limits are designed to provide reasonable protection against harmful interference in a residential installation. This equipment generates, uses, and can radiate radio frequency energy and, if not installed and used in accordance with the instructions, may cause harmful interference to radio communications. However, there is no guarantee that the interference will not occur in a particular installation. If this equipment does cause harmful interference to radio or television reception, which can be determined by turning the equipment off and on, the user is encouraged to correct the interference by one or more of the following measures:

- Reorient or relocate the receiving antenna.
- Increase the separation between the equipment and receiver.
- Connect the equipment into an outlet or circuit different that to which the receiver is connected.
- Consult the dealer or an experienced radio/TV technician for help.

Operation is subject to the following two conditions: (1) this device may not cause harmful interference, and (2) this device must accept any interference received, including interference that may cause undesired operation of this device. Modifications not expressly approved by the manufacturer could void the user's authority to operate the equipment under FCC rules.

RF Exposure Safety Notice

The TX1000 transmitter is not intended to be operated closer than 20cm (about 8 inches) to your body. The transmitter can produce a radiated RF field similar to that of a standard cell telephone, although the duty cycle of this RF field is much lower than that of a cell telephone. Using the transmitter closer than 8 inches to your body can increase your exposure to RF energy levels thought by some to be harmful. Additionally, operation in close proximity to your body can detune the antenna causing a decrease in operating performance.

The antenna(s) used for this transmitter must be installed to provide a separation distance of at least 20 cm from all persons and must not be co-located or operating in conjunction with any other antenna or transmitter. End-users and installers must be provided with antenna installation instructions and transmitter operating conditions for satisfying RF exposure compliance.

Industry Canada Notice

This device complies with Industry Canada licence-exempt RSS standard(s). Operation is subject to the following two conditions: (1) this device may not cause interference, and (2) this device must accept any interference, including interference that may cause undesirable operation of the device.

Le présent appareil est conforme aux CNR d'Industrie Canada applicable aux appareils radio exempts de licence. L'exploitation est autorisée aux deux conditions suivantes : (1) l'appareil ne doit pas produire de brouillage, et (2) l'utilisateur de l'appareil doit accepter tout brouillage radioélectrique subi, même si le brouillage est susceptible d'en compromettre le fonctionnement.

18. Warranty Statement

Your FOXPRO® game call is warranted to be free from defects in materials and workmanship that diminish its usefulness for a period of five years from the date of purchase if the item was purchased from a FOXPRO Authorized Retailer. Return the unit prepaid and packaged securely along with proof of purchase to the address shown below. Include a note describing the defect or problem. This limited warranty is void if the unit is physically damaged, used in a manner contrary to intended use, or otherwise abused, either intentionally or unintentionally. Also specifically excluded are batteries and damage caused by attempts to charge batteries not intended to be recharged, and water damage.

Online Warranty Registration

You can register your Shockwave digital game call online at the following address (locate the Warranty Registration link on the left of this page):

<http://www.gofoxpro.com/warranty>

Make sure that you retain a hard copy of your proof of purchase (i.e. store receipt) for any future warranty claims.