



586 and 686 Series

CO₂ Air Revolver
cal. .177 (4.5 mm) Pellet

Pat. applied for

⚠ WARNING: This airgun is recommended for adult use only. Careless use may cause serious injury or death. Dangerous within 450 yards (411 meters).

YOU AND OTHERS WITH YOU SHOULD ALWAYS WEAR SHOOTING GLASSES TO PROTECT YOUR EYES. READ ALL INSTRUCTIONS BEFORE USING. BUYER AND USER HAVE THE DUTY TO OBEY ALL LAWS ABOUT THE USE AND OWNERSHIP OF THIS AIRGUN.

THIS IS AN ADULT AIRGUN AND ACCORDING TO ASTM STANDARDS, IT IS EXEMPT FROM HAVING A SAFETY.

8.448.86.04.U.02-06.?.18

⚠ WARNING: Lead pellets. Do not inhale dust or put pellets in mouth. Wash hands after handling. This product contains lead, a chemical known to the State of California to cause cancer and birth defects (or other reproductive harm.)

Please read this owner's manual completely. And remember, this air revolver is not a toy. Treat it with the same respect you would a firearm. Always carefully follow the safety instructions found in this owner's manual and keep this manual in a safe place for future use. If you have any questions, regarding your new air revolver, please contact Umarex USA Customer Service at Umarex USA Inc.

6007 South 29th Street
Fort Smith, AR 72908 USA
Phone (479) 646 - 4210
Fax (479) 646 - 4206
www.umarex-usa.com.

STEPS FOR SAFE SHOOTING

1. Learning the Parts of Your New CO₂ Air Revolver
2. Insertion and Removal of CO₂ Cylinders
3. Loading and Unloading Pellets
4. Aiming and Firing Safely
5. Removing a Jammed Pellet
6. Maintaining Your Air Revolver
7. Reviewing Safety

SPECIFICATIONS
PROBLEMS
WARRANTY

1. Learning the Parts of Your New CO₂ Air Revolver

Learning the names of the parts of your new air revolver will help you to understand your owner's manual. Use this manual to increase your enjoyment of this air revolver.

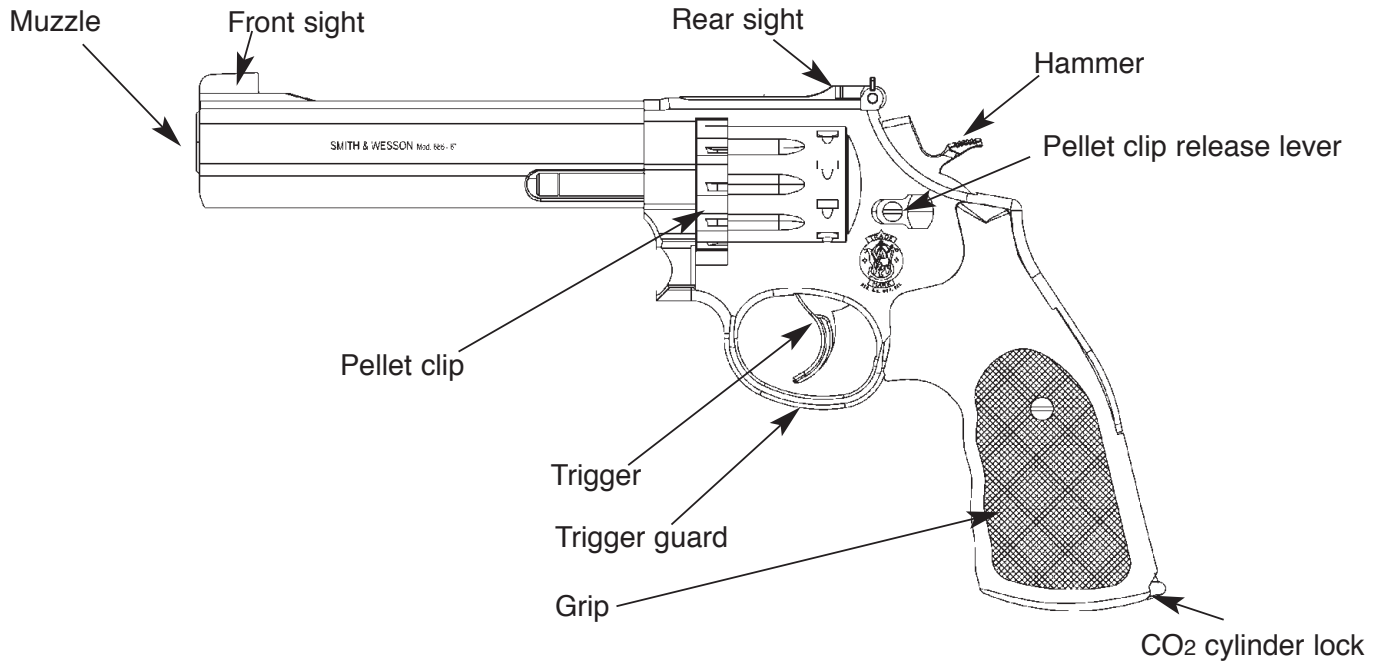

2. Insertion and Removal of CO₂ Cylinders

⚠ WARNING: CO₂ cylinders may explode at temperatures above 120° F (48.9° C). Do not mutilate or incinerate them. Do not expose them to heat or store CO₂ cylinders at temperatures above 120°F (48.9°C).

⚠ WARNING: Keep hands away from escaping CO₂ gas. It can cause frostbite if allowed to come in contact with skin.

2.1 Inserting the CO₂ Cylinder

- Make sure the air revolver is unloaded (See **Step 3.2**).
- Point the air revolver in a SAFE DIRECTION.
- If a CO₂ cylinder is already inserted, See **Step 2.2 - Removing the CO₂ Cylinder**.
- Insert the CO₂ cylinder with the small neck of the cylinder first (Fig 1.2).
- Tighten the cylinder into place by turning brass retaining screw clockwise (up) until it touches the CO₂ cylinder (Fig. 1.3). (Do not tighten it because it might damage the CO₂ cylinder).
- Replace the grip and close the CO₂ cylinder lock (Fig. 1.3). The CO₂ cylinder has now been pierced.
- With the air revolver unloaded (See **Step 3.2**) and pointed in a SAFE DIRECTION, pull the trigger to fire. **If your air revolver does not make a popping noise after pulling the trigger, the CO₂ is not being discharged.** In that event you will have to remove the CO₂ cylinder (See **Step 2.2**), and re-insert the CO₂ cylinder **as described in Step 2.1**, point in a SAFE DIRECTION, and pull the trigger.

2.2 Removing the CO₂ Cylinder

- Make sure the air revolver is unloaded (See **Step 3.2**).
- Point the air revolver in a SAFE DIRECTION.
- Open the CO₂ cylinder lock and remove the right grip cover by lifting it off from the bottom of the grip (See **Fig. 1.1**).
- Slowly turn the brass cylinder retaining screw counter clockwise (down) until it stops; allowing any remaining CO₂ gas to escape.
- Remove the CO₂ cylinder.

NOTE: High temperatures may cause damage to the air revolver. The maximum temperature for the storage or use of this air revolver should not exceed 120°F (48.9°C). This temperature can easily be reached when the air revolver is exposed to direct sunlight.

FIRING THE AIR REVOLVER WITH LOW GAS PRESSURE MAY CAUSE A PELLET TO GET STUCK IN THE BARREL.

We recommend the use of Umarex CO₂ Cylinders. They are made to fit this air revolver. Other brands of CO₂ cylinders may not fit properly and if you force them into place it may result in injury to you or damage to your air revolver. Never try to force any CO₂ cylinder into or out of place. Do not store your air revolver with a CO₂ cylinder in it. This is very important to remember, as it will prolong the longevity of your air revolver seals.

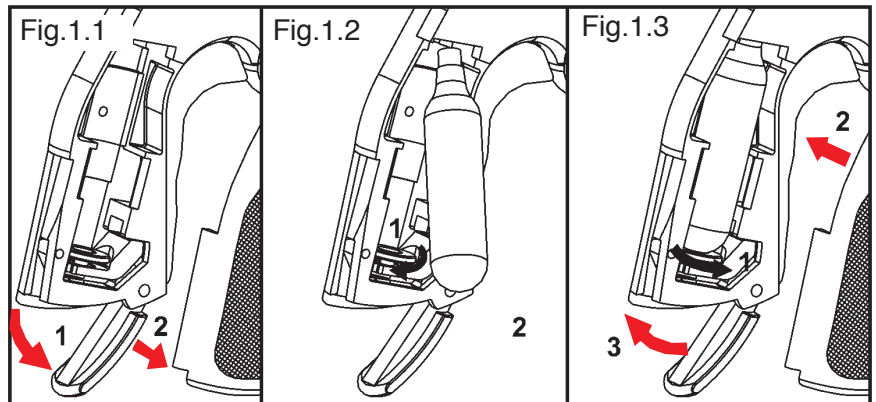

3. Loading and Unloading Pellets

▲ WARNING: Only use .177 (4.5mm) caliber pellets in this air revolver. Never reuse pellets. Use of any other ammunition can cause injury to you or damage to the air revolver.

3.1 Loading Pellets

- Press the pellet clip release lever on the left side of the frame forward to swing open the magazine to the left (Fig. 2.1).
- Remove the pellet clip from the shaft and place a .177 caliber (4.5 mm) pellet, nose first, in each pellet chamber of the pellet clip (Fig. 2.2). **IMPORTANT:** To avoid jams or deforming the pellets, make sure the pellet skirt is level or slightly below the rim of the pellet chamber.
- Place the pellet clip back on the shaft (ratchet teeth facing the rear sight) (Fig. 2.3).

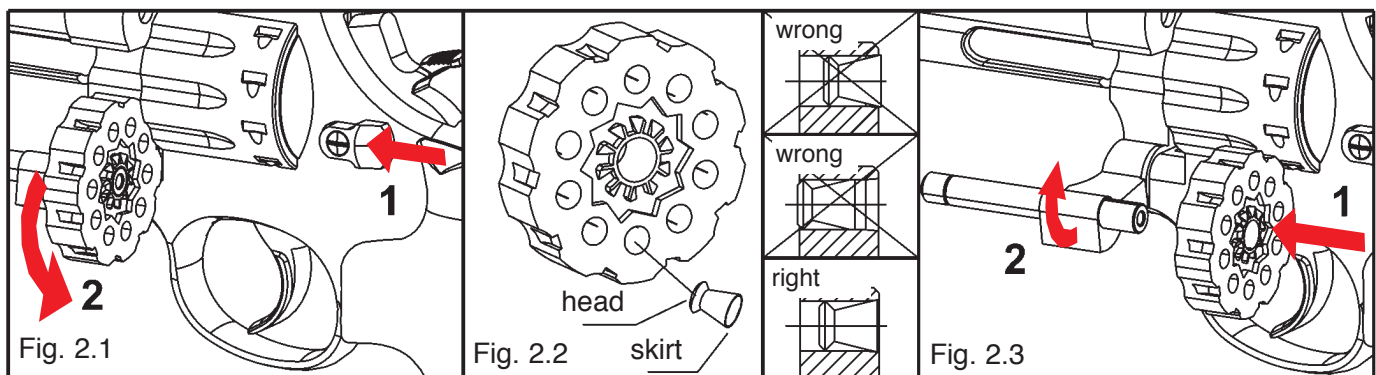

⚠ WARNING: Do not place your hand or fingers over the muzzle. Do not put your finger on the trigger and make sure your air pistol is pointing in a SAFE DIRECTION when closing the shaft. Failure to follow this warning may cause serious injury.

- Press the shaft and pellet clip back into the receiver until it snaps shut.

3.2 Unloading the Pellets

- Press the pellet magazine release lever on the left side of the frame forward to swing open the magazine to the left (Fig. 2.1).
- Remove the pellet clip from the shaft. Using a ramrod, gently push each pellet out of the pellet chamber.
- **IMPORTANT:** Never use sharp metal tools to remove pellets.
- Replace the empty pellet clip (ratchet teeth facing the rear sight) on the shaft (See Fig. 2.3).
- Close the pellet magazine until it locks into place (See Step 3.1).
- Check to make sure the barrel is completely unloaded by pointing the muzzle in a SAFE DIRECTION, cocking the hammer and squeezing the trigger to fire. You may also unload your air revolver by following the directions listed under **Step 5 - Removing a Jammed Pellet.**

4. Aiming and Firing Safely

4.1 Aiming and Firing the Air Revolver

NOTE: This air revolver will function in either "Double Action" or "Single Action" mode. To fire in "Double Action", apply steady pressure to the trigger until the pistol fires. "Single Action" mode means that the hammer has to be manually cocked prior to firing. To use "Single Action" mode, pull back the hammer and squeeze the trigger. For rapid-fire shooting, we recommend the "Double Action" mode, for more precise shooting we recommend the "Single Action" mode.

- You and others with you should always wear shooting glasses to protect your eyes.
- Always aim your air revolver in a SAFE DIRECTION. When you are sure of your target and backstop, and the area around the target is clear, point the air revolver in a SAFE DIRECTION, and squeeze the trigger to fire "Double Action" or cock the hammer and squeeze the trigger to fire "Single Action."
- Do not shoot at hard surfaces or at the surface of water. The pellet may bounce off or ricochet and hit someone or something you had not intended to hit.
- Always choose your target carefully. It is best to shoot at paper bullseye targets, which are attached to a safe backstop. Your backstop should be checked for wear before and after each use. Replace your backstop if the surface is worn or damaged, or if a ricochet occurs.
- Your air revolver is designed for target shooting and is suited for both indoor and outdoor use. Always remember to place your target carefully. THINK about what you will hit if you miss the target.
- The air revolver is correctly aimed when the front sight blade is positioned exactly in the notch of the rear sight. The top of the front sight blade should be even with the top of the notch in the rear sight. The bullseye should appear to rest on the top of the front sight (Fig. 3).

4.2 Sight Adjustment

The rear sight can be adjusted for windage and elevation

Elevation: Point of impact too high, turn the screw clockwise; point of impact too low, turn the screw counterclockwise.

Windage: Point of impact too far to the left, turn the screw clockwise; point of impact too far to the right, turn screw counterclockwise (Fig. 4).

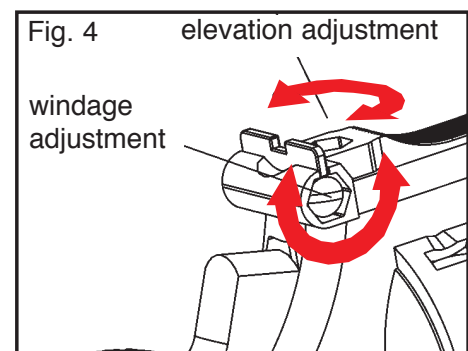
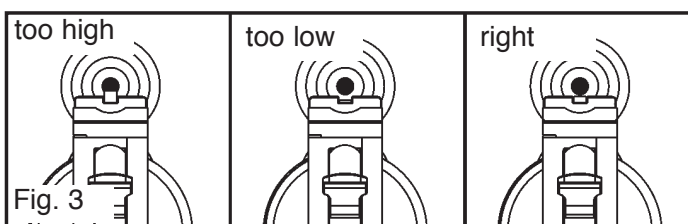

5. Removing A Jammed Pellet

IMPORTANT: The fact that the air revolver does not fire a projectile is never a reason to assume that the air-gun is not loaded. Make sure that there is no pellet jammed between the pellet clip and the barrel.

- Press the pellet magazine lever forward to swing open the magazine.
- If the jam is in the barrel, remove the pellet clip (See **Step 3.2**), insert a ramrod of the proper size into the muzzle end of the barrel and carefully push the jammed pellet into the breech. **The barrel could be damaged if the proper sized ramrod is not used.**
- Once you have pushed the pellet back into the breech, shake the air revolver until the jammed pellet falls out.
- Do not try to reuse that pellet.
- If the jam is in the pellet clip, unload pellets (See **Step 3.2**).
- **If you are not able to unjam your air revolver by following this procedure, take no further action.** Umarex USA or an Authorized Service Station will unjam your air revolver (no cost during the warranty period).

6. Maintaining Your Air Revolver

IMPORTANT: Before you attempt to oil your air revolver, always make sure the CO₂ cylinder and pellet clip are removed and you have checked the barrel to make sure there are no pellets left in it (See **Steps 2.2 & 3.2**).

- Your air revolver will maintain proper function for a long time if you oil the CO₂ cylinder lock, hinge and pellet clip release lever with 2-3 drops of lubricating oil after you have fired approximately 250 shots. **DO NOT** use a petroleum distillate based oil or solvent and **DO NOT** over-oil because this can cause damage to your air revolver.
- Tampering with the air revolver or attempts to change the air revolver in any way may make it unsafe to use and will void the warranty.
- If you drop your air revolver, check to see that it works properly before you use it again. If anything seems changed, like a shorter or weaker trigger pull, this may mean worn out or broken parts. **Call Customer Service at Umarex USA for assistance before using your air revolver again.**

7. Reviewing Safety

- Do not ever point the air revolver at any person. Do not ever point the air revolver at anything you do not intend to shoot.
- Always treat the air revolver as though it is loaded and with the same respect you would a firearm.
- Always aim in a SAFE DIRECTION. Always keep the muzzle of the air revolver pointed in a SAFE DIRECTION.
- Always check to see if the air revolver is unloaded when getting it from another person or from storage.
- Always keep your finger off the trigger and out of the trigger guard until ready to shoot.
- You and others with you should always wear shooting glasses to protect your eyes.
- Use .177 caliber pellets only. Never reuse pellets.
- Do not shoot at hard surfaces or at the surface of water. The pellet may bounce off or ricochet and hit someone or something you had not intended to hit.
- Replace the backstop if it becomes worn. Place the backstop in a location that will be safe should the backstop fail.
- Do not attempt to disassemble or tamper with your air revolver. Use an Authorized Service Station or return it to the factory for repair.
- Do not put the air revolver away loaded. Make sure **ALL** of the pellets are unloaded from the air revolver. (See **Step 3.2**)
- Do not put the air revolver away with a CO₂ cylinder inserted (See **Step 2.2**).
- Always store this air revolver in a secure location.

SPECIFICATIONS

Mechanism:	Revolver	
Caliber/Ammunition:	.177 cal (4.5 mm) Lead Airgun Pellet 	
Magazine:	10 pellets	
Sights:	Front	Removable Ramp
	Rear	Fully adjustable for windage and elevation
Weight:	5864/5864	39.9 oz. (1.13 kg)
	5866/6866	44.125 oz (1.25 kg)
	5868/6868	49.4 oz (1.40 kg)
Overall Length:	5864/6864	9.25 in. (23.5 cm)
	5866 /6866	11.2 in. (28.5 cm)
	5868/6868	13.2 in. (33.5 cm)
Barrel Length/Material:	5864/6864	4 in. (10.16 cm) /Rifled steel
	5866 /6866	6 in (15.24 cm)/ Rifled steel
	5868/6868	8 in. (20.32 cm)/ Rifled steel
Power source	CO ₂ 12-gram small neck cylinders	
Safety:	Adult gun under ASTM standards; no manual safety	
Velocity:	5864/6864	Up to 396 fps (120.7 m/s)
	5866 /6866	Up to 426 fps (129.8 m/s)
	5868/6868	Up to 458 fps (139.6 m/s)

PERFORMANCE

Many factors affect velocity, including brand of projectile, type of projectile, amount of CO₂ in cylinder, lubrication, barrel condition and temperature.

REPAIR SERVICE

If your air pistol needs repair, we recommend that you take or send it to an Authorized Service Station or Umarex USA. **For an Authorized Service Station near you, visit our web site at www.umarex-usa.com or call Customer Service at (479) 646 - 4210. (International customers should contact their distributor.)** DO NOT ATTEMPT TO DISASSEMBLE IT! Your air pistol requires special tools and fixtures to repair it. If you take it apart, you probably will not be able to reassemble it correctly. Umarex USA assumes no warranty responsibility under such circumstances.

LIMITED ONE YEAR WARRANTY

This product is warranted to the retail consumer for one year from date of retail purchase against defects in material and workmanship and is transferable.

WHAT IS COVERED

Replacement parts and labor. Transportation charges to consumer for repaired product.

WHAT IS NOT COVERED

Transportation charges to Umarex USA for defective product. Damages caused by abuse or failure to perform normal maintenance. (See **Step 6**) Any other expense. CONSEQUENTIAL DAMAGES, INCIDENTAL DAMAGES, OR INCIDENTAL EXPENSES, INCLUDING DAMAGE TO PROPERTY. SOME STATES DO NOT ALLOW THE EXCLUSION OR LIMITATION OF INCIDENTAL OR CONSEQUENTIAL DAMAGES, SO THE ABOVE LIMITATION OR EXCLUSION MAY NOT APPLY TO YOU.

WARRANTY CLAIMS

Warranty Claims for U.S. and Canadian Customers:

Please return product to your nearest distributor. If you do not know your distributor, please visit www.umarex-usa.com and click on "warranty and repair service" or call (479) 646 - 4210 and ask for our assistance.

IMPLIED WARRANTIES

ANY IMPLIED WARRANTIES, INCLUDING THE IMPLIED WARRANTIES OF MERCHANTABILITY AND FITNESS FOR A PARTICULAR PURPOSE, ARE LIMITED IN DURATION TO ONE YEAR FROM DATE OF RETAIL PURCHASE. SOME STATES DO NOT ALLOW LIMITATIONS ON HOW LONG AN IMPLIED WARRANTY LASTS, SO THE ABOVE LIMITATIONS MAY NOT APPLY TO YOU.

To the extent any provision of this warranty is prohibited by federal, state, or municipal law which cannot be preempted, it shall not be applicable. This warranty gives you specific legal rights, and you may also have other rights which vary from state to state and country to country.

Problems

Problem	POSSIBLE CAUSE	Empty CO2 cylinder	Dirty barrel	Defective CO2 cylinder	Extreme temperatures	Wrong ammunition	Pellets loaded upside down	Pellet Magazine not locked	Incorrect sight adjustment
Inferior accuracy	●	●		●	●	●		●	
Air revolver does not fire	●	●	●	●		●	●		
Low velocity	●	●		●	●	●			



Distributed by

Umarex USA Inc.
 6007 South 29th Street
 Fort Smith, AR 72908 USA
 Phone (479) 646 - 4210
 Fax (479) 646 - 4206
www.umarex-usa.com