

Model 1720T  
.177 Caliber Pre-Charged  
Pneumatic Airgun  
**OWNER'S MANUAL**  
READ ALL INSTRUCTIONS AND WARNINGS IN  
THIS MANUAL BEFORE USING THIS AIRGUN



Crosman Corporation  
7629 Routes 5 & 20  
Bloomfield, NY 14469 USA  
www.crosman.com  
1-800-7AIRGUN (724-7486)  
Made in USA with some foreign components

1720T-515

**WARNING:** Not a toy. This airgun is recommended for adult use only. Misuse or careless use may cause serious injury or death. May be dangerous up to 450 yards (411 m).

**WARNING:** Do not brandish or display this airgun in public—it may confuse people and may be a crime. Police and others may think it is a firearm. Do not change the coloration and markings to make it look more like a firearm. That is dangerous and may be a crime.

This air pistol has been classified as a match precision air pistol. Because it is considered a special purpose air pistol, it is exempt from specific types of testing. Specifically this air pistol was NOT subjected to the trigger pull or drop test requirements.

**CAUTION:** The adjustable trigger can be adjusted below 3 lbs, and when it is adjusted below 3 lbs, the air pistol could fire when dropped  
**YOU AND OTHERS WITH YOU SHOULD ALWAYS WEAR SHOOTING GLASSES TO PROTECT YOUR EYES.**

**BUYER AND USER HAVE THE DUTY TO OBEY ALL LAWS ABOUT THE USE AND OWNERSHIP OF THIS AIRGUN.**

**THIS AIRGUN IS INTENDED FOR USE BY ADULTS ONLY**

**WARNING:** This product contains a chemical known to the state of California to cause cancer and birth defects (and other reproductive harm).

**WARNING:** Use only compressed air in this airgun. Use no other gasses—including oxygen, which can cause a fire or explosion that may result in serious injury or death.

Read this owner's manual completely. And remember that an airgun is not a toy. Always carefully follow the safety instructions in this owner's manual and keep the manual in a safe place for future use. If you have any questions regarding the operation of your new airgun contact Crosman at 1-800-724-7486.

## 1. Learning the Parts of your New Airgun

Learning the names and parts of your new airgun helps you understand your owner's manual.

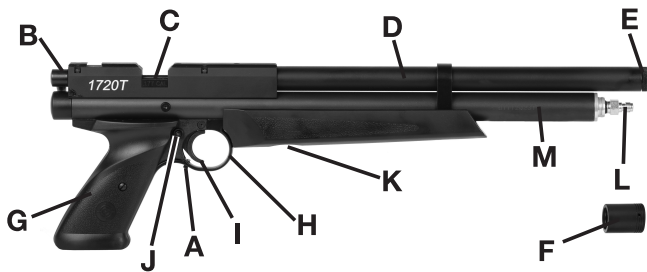

- A. Trigger Over travel screw
- B. Bolt handle
- C. Breech
- D. Barrel
- E. Muzzle
- F. Protective cap
- G. Grip
- H. Trigger guard
- I. Trigger
- J. Safety
- K. Pressure gauge
- L. Fill nipple
- M. Pressure Reservoir

## 2. Operating the Safety

### A. To Put the Air Pistol "ON SAFE:"

- Locate the safety directly in back of the trigger.
- Push the safety from the left side all the way in (Fig. 2). The safety is not "ON SAFE" unless it is pushed all the way in and the RED ring around the left side of the safety is NOT showing.

Like all mechanical devices, an air pistol safety can fail. Even when the safety is "ON SAFE", you should continue to handle the air pistol safely.

**NEVER** point the air pistol at any person. **NEVER** point the air pistol at anything you do not intend to shoot

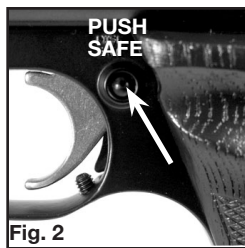

Fig. 2

### B. To Take the Air Pistol "OFF SAFE":

- Push the safety from the right side all the way in.
- The air pistol is ready to fire when "OFF SAFE". When you can see the RED line on the left side of the safety, the air pistol is "OFF SAFE" and can be fired.

## 3. Pressurizing the Airgun

**WARNING:** Use only compressed air in this airgun. Use no other gasses—including oxygen, which can cause a fire or explosion that may result in serious injury or death.

### A. Pressurizing (Filling) the Airgun with a Hand Pump

- Be sure to wear eye protection.
- Make sure the airgun is unloaded and not cocked. (See section 4 for instructions on unloading and un-cocking.)
- Read all instructions with your hand pump so you are familiar with its operation. Use only a pump designed for filling a pre-charged airgun and outfitted with a Foster #12FS or #12FSS quick disconnect fitting. Do not use a standard air compressor or bicycle pump.
- Put the airgun "ON SAFE" (see section 2A) and point in a SAFE DIRECTION.
- Pull off the protective cap that covers the fill nipple on the airgun.
- Connect the quick-disconnect fitting on the hand pump hose to the fill nipple (fig. 3.) by
  - Pulling back and holding the knurled ring
  - Connecting the fitting over the fill nipple.
  - Releasing the knurled ring and push it forward to lock the fitting on to the fill nipple.
- Make certain the bleed valve on the hand pump is fully closed (tighten in a clockwise direction) (fig.4).
- Start pumping and continue until the gauge needles on your pump and on the airgun are between 2500 psi and 3000 psi depending on your desired tune. DO NOT fill the air gun to more than 3000 psi (207 bar). See "Overfill" information (section 3C).

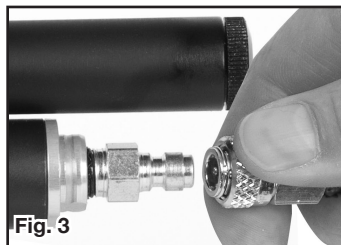

Fig. 3

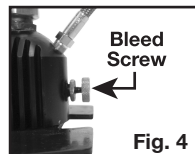

Fig. 4

**WARNING:** Disconnecting the fill hose from the airgun without bleeding the air first may result in injury from hose whip as a result of pressure in the fill hose.

- Open the bleed screw on the pump base rapidly in a counter-clockwise direction to COMPLETELY bleed the hose. You must bleed the fill hose COMPLETELY to avoid hose whip from pressure in the fill hose.
- Disconnect the pump from the fill nipple on the gun
- Replace the cap over the fill nipple. Always keep the fill nipple capped to eliminate the possibility of dirt entering the check valve.

## B. Pressurizing (Filling) the Airgun with a High Pressure Tank

The 1720T may be filled from a high pressure tank (bottle). Scuba style tanks designed for 3000 psi pressures and above are best suited for the task as they can fill the 1720T many times to 2500-3000 psi. For scuba tanks use the Crosman FAH003 Scuba Yoke Adapter for K style valves or the FAH004 DIN style Adapter for DIN style valves.

- Be sure to wear eye protection.
- Make sure the airgun is unloaded and not cocked.
- (See section 4 for instructions on unloading and un-cocking.)
- Read all instructions with your tank so you are familiar with its operation.
- Put the airgun "ON SAFE" (see section 2A).
- Point the airgun in a SAFE DIRECTION.
- Remove the cap that covers the fill nipple on the airgun.
- Connect the quick-disconnect fitting on the adaptor's hose to the fill nipple (fig. 3).
- Slowly open the valve on your tank and start filling the gun SLOWLY. Filling too quickly will cause heat buildup that can affect accuracy of the fill pressure.
- Watch the gauges on the airgun and your tank (if equipped) until the desired pressure is reached (2500 - 3000 psi) DO NOT fill the airgun to more than 3000 psi. See "Overfill" information in section 3C.
- Turn the valve on your tank off when the desired fill pressure is reached.
- Follow instructions with your tank and hose to BLEED the fill hose COMPLETELY to avoid hose whip from pressure in the fill hose
- Disconnect the tank's fill hose from the fill nipple on the airgun.
- Replace the cap over the fill nipple. Always keep the fill nipple capped to eliminate the possibility of dirt entering the check valve.

**TIP:** If your airgun is being filled from completely empty (zero pressure) the tension of the hammer pressing against the valve may keep the valve open which causes air to leak down the barrel. This is most likely to happen with a gun where the hammer spring is adjusted to a high rate. In the event this occurs try cocking the bolt and leaving it in the rear (fully open) position to eliminate the force on the valve allowing it to close. Always make certain the airgun is not loaded and there is not a pellet in the chamber.

**TIP:** Pressurizing the airgun causes heat which in turn will register a higher pressure. Always **fill slowly** and allow the reservoir to cool to obtain the most accurate fill pressure. Topping off the reservoir after it is allowed to cool is recommended.

## C. Overfill:

- Over filling beyond the "as tuned" best fill pressure does not improve performance. It lessens performance and may cause the valve to lock. For instance a gun tuned for best performance at 2,500 psi may partially valve lock at 3000 psi. If you discover that the airgun has been over filled, try to dry fire the airgun (cock and shoot with no pellet loaded) in a SAFE DIRECTION until the pressure on your airgun drops to the pressure where your gun was tuned to perform best.
- If the airgun will not discharge air with each shot, the valve may be completely pressure locked and require use of the degassing tool PCPDT4 available at [www.crosman.com](http://www.crosman.com) , or contact Crosman Customer Service at 1-800-724-7486.

## D. Depressurizing the Airgun

- Keep the pistol pointed in a SAFE DIRECTION.
- Remove all the air from your pistol by repeatedly cocking and dry-firing with the pistol pointed in a SAFE DIRECTION until the pressure gauge on your airgun shows no pressure on the gauge and air cannot be heard when the gun is dry fired.
- Put the airgun "ON SAFE".
- If the pressure in the gun cannot be relieved using the dry firing process it may indicate a valve lock condition and require use of the degassing tool PCPDT4 available at [www.crosman.com](http://www.crosman.com) , or contact Crosman Customer Service at 1-800-724-7486.

## 4. Cocking, Loading, Unloading and Uncocking the Airgun

**⚠ WARNING:** Use .177 caliber pellets only in your airgun. Never reuse ammunition. Use of any other ammunition can cause injury to you or damage to the airgun.

### A. Cocking and Loading Pellets

- Put the airgun "ON SAFE" (see section 2A) and point in a SAFE DIRECTION.
- Be sure your airgun is properly pressurized (see section 3).
- Open the bolt by pushing the bolt handle up and pulling it all the way back. With the bolt in the rearward position, place one pellet, nose first, into the loading tray. This is a single shot pellet airgun. Load no more than one pellet at a time.
- Lightly push the pellet into the barrel by closing the bolt and pushing the bolt handle down to lock. DO NOT jam the bolt forward. This will damage your airgun.
- Be sure the bolt is closed and locked before firing. If it is not closed and fully locked, the pellet may not be discharged.

## B. Unloading Pellets

- The most common way to unload a pellet is to fire your airgun in a SAFE DIRECTION following section 5 on Aiming and Firing Safely. If a pellet has become lodged in the barrel follow the steps in section 6 Removing a Jammed Pellet.

## C. Un-cocking

- To uncock the action, take the airgun "OFF SAFE." With the muzzle pointed in a SAFE DIRECTION, open the bolt and pull all the way to the rear. Holding the bolt handle securely, pull the trigger with your other hand and slowly ease the bolt as far forward as it will go with your hand. You may now lower the bolt and the airgun is un-cocked.
- Put the airgun "ON SAFE".

## 5. Aiming and Firing Safely

- Always point your airgun in a SAFE DIRECTION.
- Follow the instructions for filling the air gun (section 3) and loading pellets (section 4A).
- You and others with you should always wear shooting glasses to protect your eyes.
- Do not shoot at hard surfaces or at the surface of water. The pellet may bounce off or ricochet and hit someone or something you had not intended to hit.
- Always choose your target carefully. It is best to shoot at paper bull's-eye targets attached to a safe backstop. A heavy blanket should be hung behind the backstop to prevent ricochet should you miss the backstop.
- Your airgun is designed for target shooting and is suited for both indoor and outdoor use. Always remember to place your target carefully. THINK about what you will hit if you miss the target.
- Before firing the airgun make certain there is sufficient pressure for proper operation.

## 6. Removing a Jammed Pellet

A jammed pellet is usually the result of trying to fire the airgun when the pressure is too low. Before firing the airgun make certain there is sufficient pressure for proper operation, by making sure the gauge needle is pointing to the area between 1000 and 3000 psi.

**WARNING:** In this procedure you will put a cleaning rod down the barrel of a charged airgun. It is extremely important that while you are doing this the airgun be "ON SAFE", the bolt remains in open position and that your finger be kept away from the trigger. Failure to follow this warning may result in serious injury or death.

- Point the airgun in a SAFE DIRECTION.
- Put the airgun "ON SAFE" (see section 2A.)
- Open the bolt by pushing the bolt handle up and pulling it all the way back.
- With the bolt in the rearward position insert a ramrod of the proper size into the barrel (start at the muzzle). (fig. 6) The barrel could be damaged if the proper sized cleaning rod is not used.



**Note:** The bolt must be cocked and open for the jammed pellet to clear the breech when it is pushed out by the ram rod.

- Using the ramrod push the pellet into the pellet loading port (forward of the bolt), remove and discard the pellet. Do not reuse that pellet.
- Point the airgun in a SAFE DIRECTION. Close the action take "OFF SAFE" and fire.
- Put the airgun "ON SAFE" (see section 2A.)
- If you are not able to unjam your airgun by following this procedure, take no further action. Crosman Corporation or an Authorized Service Station will unjam your airgun. (no cost during the warranty period)

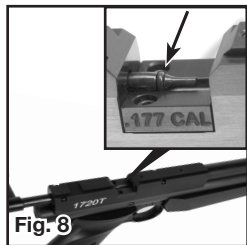

## 7. Maintaining Your Airgun

**WARNING:** Use of petroleum-based lubricants in the pressure reservoir could result in an explosion resulting in personal injury.

- Keep all petroleum-based lubricants away from the fill nipple. They MUST NOT be introduced into the high pressure reservoir.
- Apply Crosman silicone chamber oil (part number RMCOIL) on the bolt o-ring every 3 months or 500 shots (fig. 7)
- Apply a moly graphite EP (Extreme Pressure) grease to the sliding bolt mechanism every 3 months or 500 shots.

**DO NOT MODIFY OR ALTER YOUR AIRGUN.** Attempts to modify the airgun in any way inconsistent with this manual may make your airgun unsafe to use, cause serious injury or death, and will void the warranty. If you drop your airgun, visually check to see that it works properly before you use it again. If anything seems changed, like a shorter or weaker trigger pull, this may mean worn out or broken parts. Call Crosman customer service for assistance before using your airgun again.

**WARNING:** Do not attempt to repair the airgun or to disassemble to correct an over fill or valve lock. Parts can fly from the airgun at dangerous speeds when it is disassembled while pressurized.

## 8. Changing the Bolt Direction

The bolt direction on your 1720T PCP pistol is capable of being changed to the opposite hand. The 1720T is factory assembled to accommodate a right handed shooter by having the bolt pointing left. This allows cocking of the bolt and loading pellets with the left hand while maintaining the grip hold with the right. Disassembly of the Breech and Barrel assembly from the Reservoir Tube assembly is required to access the parts contained within the Breech that facilitate the change to the opposite hand. Crosman Corporation recommends the use of an approved Service Station to perform the change. An approved Service Station may be found through [www.crosman.com](http://www.crosman.com) or by calling Customer Service at 1-800-724-7486.

## 9. Advanced Tuning Techniques

### A. Adjusting the Trigger (Overview)

The Marauder pistol trigger assembly can be adjusted to achieve a variety of trigger profiles. It has been factory set for a two stage profile but can also be changed to a single stage. Unless you are experienced in making such adjustments, Crosman recommends that adjustments to factory settings be made only by a qualified gunsmith after reading all instructions.

**WARNING:** Adjusting the trigger assembly can result in a light trigger pull and or decreased sear engagement that could make the gun more susceptible to discharge when dropped or jarred WITH OR WITHOUT THE SAFETY ENGAGED. Make only the adjustments identified in this manual.

**NOTE:** These adjustment features are for advanced shooters. Most shooters can use the factory settings and should not need to make modifications.

- Put the air pistol "ON SAFE", remove the clip and keep the air pistol pointed in a SAFE DIRECTION.
- Depressurize the air pistol (see section 3D).
- Remove the right side Grip Screw and Grip using a straight blade screw driver.

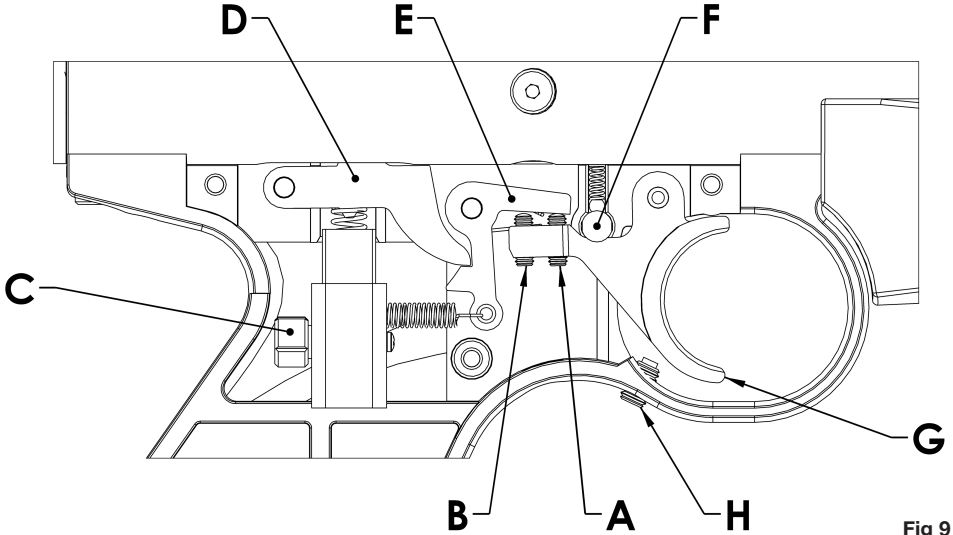

Fig 9

A. FIRST STAGE ADJUSTER B. SECOND STAGE ADJUSTER C. TRIGGER WEIGHT ADJUSTER  
D. SEAR E. LINK F. SAFETY G. TRIGGER H. TRIGGER OVERTRAVEL SCREW

### Trigger Pull

Locate the Trigger Weight Adjuster Screw C (Fig. 8). Viewed from the shooting vantage point, turn clockwise (Fig 9A) to increase trigger pull weight and counterclockwise to decrease trigger pull weight. This adjustment will not affect sear engagement.

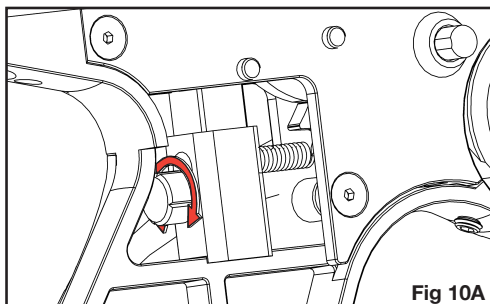
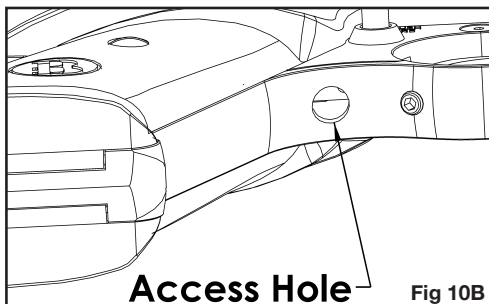

Fig 10A



Access Hole

Fig 10B

## B. Two Stage Trigger Adjustment

- **Trigger Stage Adjuster Screws:** Locate the stage adjustment screws access hole on the underside of the Grip Frame (Fig. 9B). Using a .050" Allen wrench for adjustment of screws (A) and (B), changes can be made to the position and length of first and second stages of the trigger motion. These adjustments could affect sear engagement, and therefore could allow the gun to fire when dropped or jarred.
- Screw (A) changes the first stage. Turning screw (A) clockwise will increase the length of the first stage and decrease the sear engagement. Turning counter clockwise will decrease the length of the first stage and increase the sear engagement.
- Screw (B) changes the second stage. Turning screw (B) clockwise will cause the second stage to occur sooner while turning counterclockwise will cause the second stage to occur later.
- Adjustment of screws (A) and (B) should be done in harmony with each other as they work together to create the trigger's profile. Start slowly to understand what each adjustment does and its relationship to the other.
- After adjusting your trigger, always check that the trigger and safety are functioning properly. If you are not sure if the trigger or safety is operating properly, take your gun to an experienced gunsmith.
- Replace the Grip and Grip screw.

## C. Single Stage Trigger Adjustment

- **Trigger Stage Adjuster Screws:** Locate the stage adjustment screws access hole on the underside of the Grip Frame (Figure 9B).
- For creating a single stage trigger, adjust screw (A) clockwise until the desired Sear engagement is attained. Adjusting screw (A) in this manner will eliminate engagement of screw (B) and will yield the lightest possible single stage trigger pull. Screw (B) can also be utilized to create single stage trigger by turning in clockwise until the desired Sear engagement is attained. It is advised to also turn Screw (A) out counter-clockwise a few turns to ensure it is no longer engaged at any point. Which screw is utilized to create the single stage trigger depends on the preference of the individual.
- After adjusting your trigger, always check that the trigger and safety are functioning properly. If you are not sure if the trigger or safety is operating properly, take your gun to an experienced gunsmith.
- Replace the Grip and Grip screw.

## D. Maintaining the Marauder Pistol Trigger

- The Marauder pistol trigger is assembled with a moly graphite EP grease that should last for years. In the event your trigger becomes contaminated with debris and is not functioning properly, contact a qualified gunsmith to examine for repair or necessary maintenance.

## E. Adjusting the Trigger Over-travel

- To ensure crisp, consistent action of the trigger, a set screw has been incorporated into the trigger guard to allow each shooter to set the trigger over-travel to their preference. Removing the screw will give the most over travel, tightening the screw all the way in will stop the trigger. Shooters will find their preference somewhere in between.
- Make sure the air pistol is unloaded (section 4B) and de-gassed (section 3D)
- Turn the set screw (H) as shown in Figure 8, all the way in with a hex wrench. (not included)
- Cock the bolt by pushing the bolt handle up and pulling it all the way back. Close the bolt and push the bolt handle down to lock.
- Point the air pistol in a SAFE DIRECTION, take "OFF SAFE" (section 2B) and pull the trigger. If the pistol does not fire, turn the set screw counter clockwise in ½ turn increments until it fires.



Fig 11

**IMPORTANT!** Turn an additional ½ turn counter clockwise. This is important to ensure proper operation of the trigger.

- Put the air pistol "ON SAFE".

## 10. Adjusting for Various Fill Pressures and Velocities

- Proper adjustment of the 1720T requires use of a chronograph.
- The 1720T has been factory set for a fill pressure of **2900 psi** and velocity up to 750 fps. These settings will suit most target uses and will yield a long usable shot string. If you, as the owner, wish to alter the factory settings you should do so only after reading the following instructions carefully.



- The 1720T is designed to be tuned to work at various fill pressures from 2500 psi (172 bar) up to 3000 psi (207 bar). This is done by adjustment of the hammer spring preload and hammer stroke length. In either case the adjustment changes the amount of energy the hammer generates when striking the valve. Higher fill pressures require more hammer energy while lower fill pressures require less hammer energy. Higher fill pressures will typically yield more usable shots from a given charge. It is advised to always record your settings when tuning your airgun.
- The 1720T can be adjusted to achieve various velocities using the same procedures described herein. This would mainly be done to compensate for heavier pellets IE 10.5 grain vs. 7

### A. Hammer Spring Preload Adjuster

The hammer spring preload adjuster may be accessed through the rear plug on the reservoir tube with a 3/16" Allen wrench as shown in figure 11. To increase hammer energy turn the preload adjuster clockwise up to 7 revolutions. This would be the case when starting from all the way back counterclockwise.

**NOTE:** More revolutions will simply cause the adjuster to spin but will not yield any higher force. Increasing the preload will be required to facilitate use of higher fill pressure.

To lessen hammer energy turn the adjuster counterclockwise. It is advised to always record your settings when tuning your airgun.



Fig. 12

### B. Stroke Adjustment

The striker can be accessed through the hammer spring preload adjuster using a 1/8" Allen wrench (fig 12). Turning the striker clockwise will shorten the hammer stroke and turning counter clockwise will lengthen the stroke. A long stroke length will yield higher hammer energy while a short stroke length will yield lower hammer energy. The striker can be adjusted inward by up to 12 revolutions though this many turns would never be necessary.

- A starting point for low fill pressures would start with a low hammer spring preload tension and a shorter hammer stroke.
- A starting point for higher fill pressures will require more hammer spring preload tension and a longer hammer stroke. Refer to the chart below for suggested combinations of these adjustments based on fill pressure.

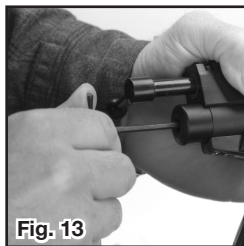

Fig. 13

Fill Pressure	Hammer Spring Preload	Hammer Stroke
Higher	Increase, turn adjuster in (Clockwise)	Increase. Turn Striker out (Counter Clockwise)
Lower	Decrease, turn Adjuster out (Counter Clockwise)	Decrease. Turn Striker in (Clockwise)

### Transfer Port Change:

As well as fine tuning adjustments possible with the Hammer pre-load and Striker settings, this pistol is included with a smaller (.047" diameter) transfer port. Changing to the smaller diameter transfer port will lessen the velocity achievable to approximately 550 fps max (depending on pellet weight) and increase the number of shots to approximately 70 per fill. The lower velocity is intended for Silhouette shooting matches where higher energies that may re-set or damage targets is undesirable. Be aware that changes to the velocity will affect sight settings. The transfer Port change is meant as a one-time change to set the pistol permanently and not a more "on the fly" type of change. Seek the aid of a Crosman Service station or qualified Gunsmith to change the Transfer Port.

## 11. Reviewing Safety

- Never point the airgun at any person or at anything you do not intend to shoot.
- Always treat the airgun as though it is loaded and with the same respect you would a firearm.
- Always aim in a SAFE DIRECTION. Always keep the muzzle of the airgun pointed in a SAFE DIRECTION.
- Always keep the airgun on safe until you are ready to shoot.
- Always check to see if the airgun is "ON SAFE" (see section 2A) and unloaded when getting it from another person or from storage.
- Always keep your finger off the trigger and out of the trigger guard until ready to shoot.
- You and others with you should always wear shooting glasses to protect your eyes.
- If your reading, or prescription, glasses are not safety glasses, make sure you wear shooting glasses over your regular glasses.
- Use .177 caliber (4.5mm) pellets only in your airgun. NEVER reuse ammunition.
- Do not shoot at hard surfaces or at the surface of water. The pellet may bounce off or ricochet and hit someone or something you had not intended to hit.
- Place the backstop in a location that will be safe should the backstop fail.
- Your backstop should be checked for wear before and after each use. All backstops are subject to wear and will eventually fail. Replace your backstop if the surface is worn or damaged or if a ricochet occurs.
- Do not attempt to disassemble or tamper with your airgun. Use an Authorized Service Station. Using unauthorized repair centers or modifying the function of your airgun in any way may be unsafe and will void your warranty.

- Store airgun in a secure location.
- Before you store your airgun, make sure there is no pellet in the chamber and make sure the gun is uncocked (see section 4C).
- Store this airgun charged with air to keep the valves closed against dirt.
- Whenever you store the airgun, make sure it is "ON SAFE" (see section 2A.)

## SPECIFICATIONS

<b>Mechanism/Action</b>	Bolt Action	<b>Weight</b>	2.7 lbs.
<b>Capacity</b>	Single Shot	<b>Length</b>	18.0 Inches
<b>Power source</b>	Compressed Air	<b>Barrel</b>	Rifled, Choked and Crowned
<b>Caliber/Ammo</b>	.177 Caliber Pellet	<b>Safety</b>	Cross Bolt
<b>Velocity</b>	<b>Factory Setting:</b> Silver Transfer (.067") Adjustable, up to 750 fps with 7.9g pellet <b>Optional Setting:</b> Red Transfer (.047") Adjustable, up to 550 fps with 7.9g pellet		
<b>Shots Per Fill</b>	<b>Factory Setting:</b> Silver Transfer (.067") Up to 30 <b>Optional Setting:</b> Red Transfer (.047") Up to 70		

### DO NOT RETURN THIS PRODUCT TO THE STORE.

Our friendly customer service representatives will be glad to help. You can get answers to frequently asked questions at [www.crosman.com](http://www.crosman.com) or you can contact us directly at 1-800-7AIRGUN (1-800-724-7486)

## REPAIR SERVICE

If your airgun needs repair, we recommend you take or send it to your nearest Crosman Authorized Service Station. **DO NOT ATTEMPT TO DISASSEMBLE IT!** Your airgun requires special tools and fixtures to repair it. Any disassembly or modification not performed by an Authorized Service Station voids the warranty.

### A SPECIAL CUSTOMER SERVICE

Crosman Authorized Service Stations will unjam your airgun at no cost during the warranty period.

### LIMITED ONE YEAR WARRANTY

This product is warranted to the retail consumer for one year from date of retail purchase against defects in material and workmanship and is transferable. To register the serial number of your air pistol return the air pistol registration form. The warranty is not conditioned on the return of the card. You should retain the original sales receipt as record of date of purchase.

### WHAT IS COVERED

Replacement parts and labor. Transportation charges to consumer for repaired product.

### WHAT IS NOT COVERED

Transportation charges to Authorized Service Station for defective product. Damages caused by abuse, modification or failure to perform normal maintenance – see Owner's Manual. Any other expense. CONSEQUENTIAL DAMAGES, INCIDENTAL DAMAGES, OR INCIDENTAL EXPENSES INCLUDING DAMAGE TO PROPERTY. SOME STATES DO NOT ALLOW THE EXCLUSION OR LIMITATION OF INCIDENTAL OR CONSEQUENTIAL DAMAGES SO THE ABOVE LIMITATION OR EXCLUSION MAY NOT APPLY TO YOU.

### HOW TO OBTAIN WARRANTY PERFORMANCE

**U.S. Customers-** Locate nearest service station (see [www.Crosman.com](http://www.Crosman.com) or call Crosman customer service at 800-724-7486 for list of stations). The service station will give you details of how to proceed with sending the item in for repair. You must contact the station prior to shipping your product.

**International Customers-** Please return product to your nearest distributor. If you do not know your distributor, please call 585-657-6161 and ask for our International Department for assistance.

### IMPLIED WARRANTIES

ANY IMPLIED WARRANTIES INCLUDING THE IMPLIED WARRANTIES OF MERCHANTABILITY AND FITNESS FOR A PARTICULAR PURPOSE ARE LIMITED IN DURATION TO ONE YEAR FROM DATE OF RETAIL PURCHASE. SOME STATES DO NOT ALLOW LIMITATIONS ON HOW LONG AN IMPLIED WARRANTY LASTS SO THE ABOVE LIMITATIONS MAY NOT APPLY TO YOU.

To the extent any provision of this warranty is prohibited by federal, state or municipal law, which cannot be preempted, it shall not be applicable. This warranty gives you specific legal rights and you may also have other rights, which vary, from state to state.

CROSMAN is a registered trademark of Crosman Corporation in the United States.